

breezesta™

SKYLINE CAPTAINS BAR CHAIR
BH-0902

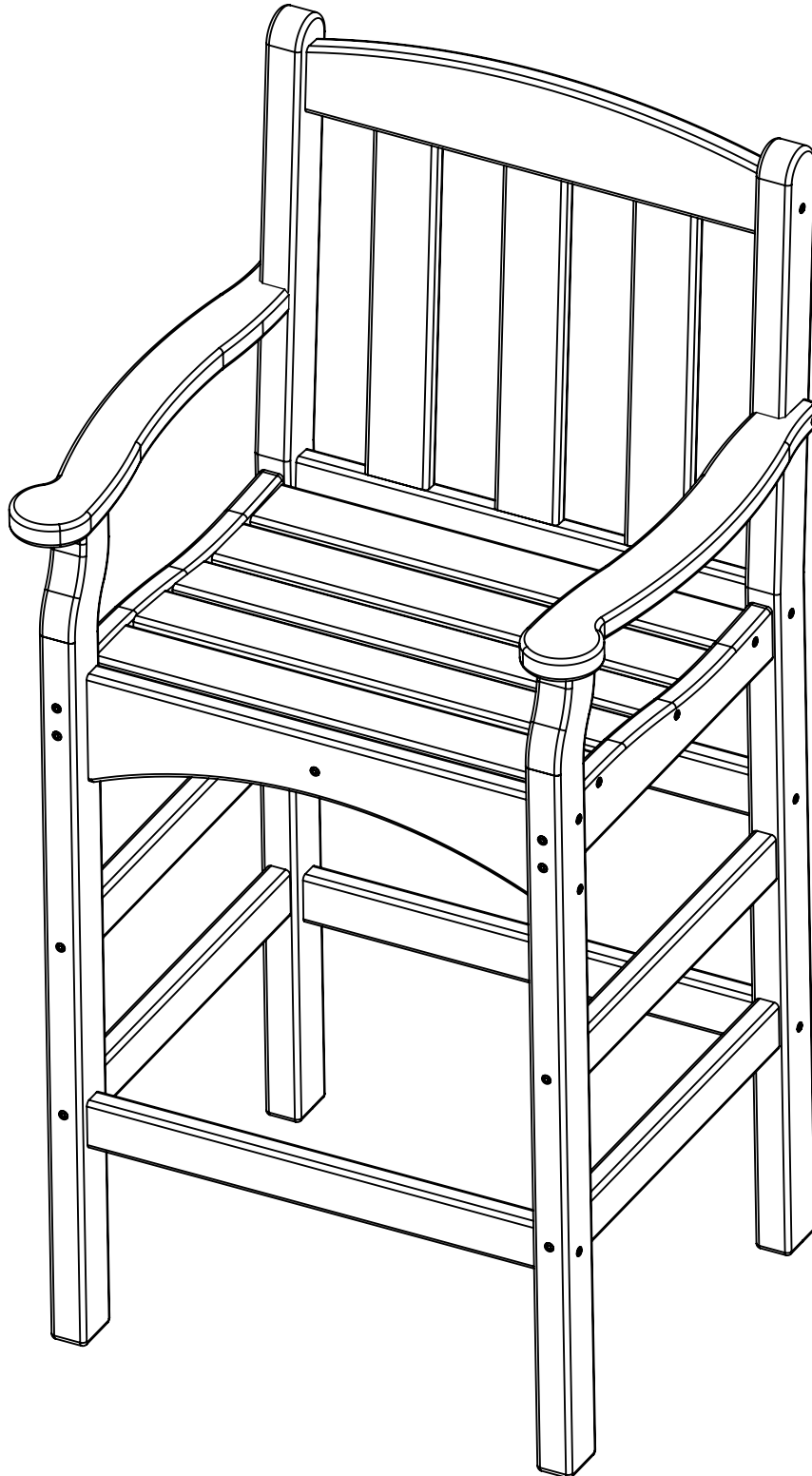

REV00-1/19

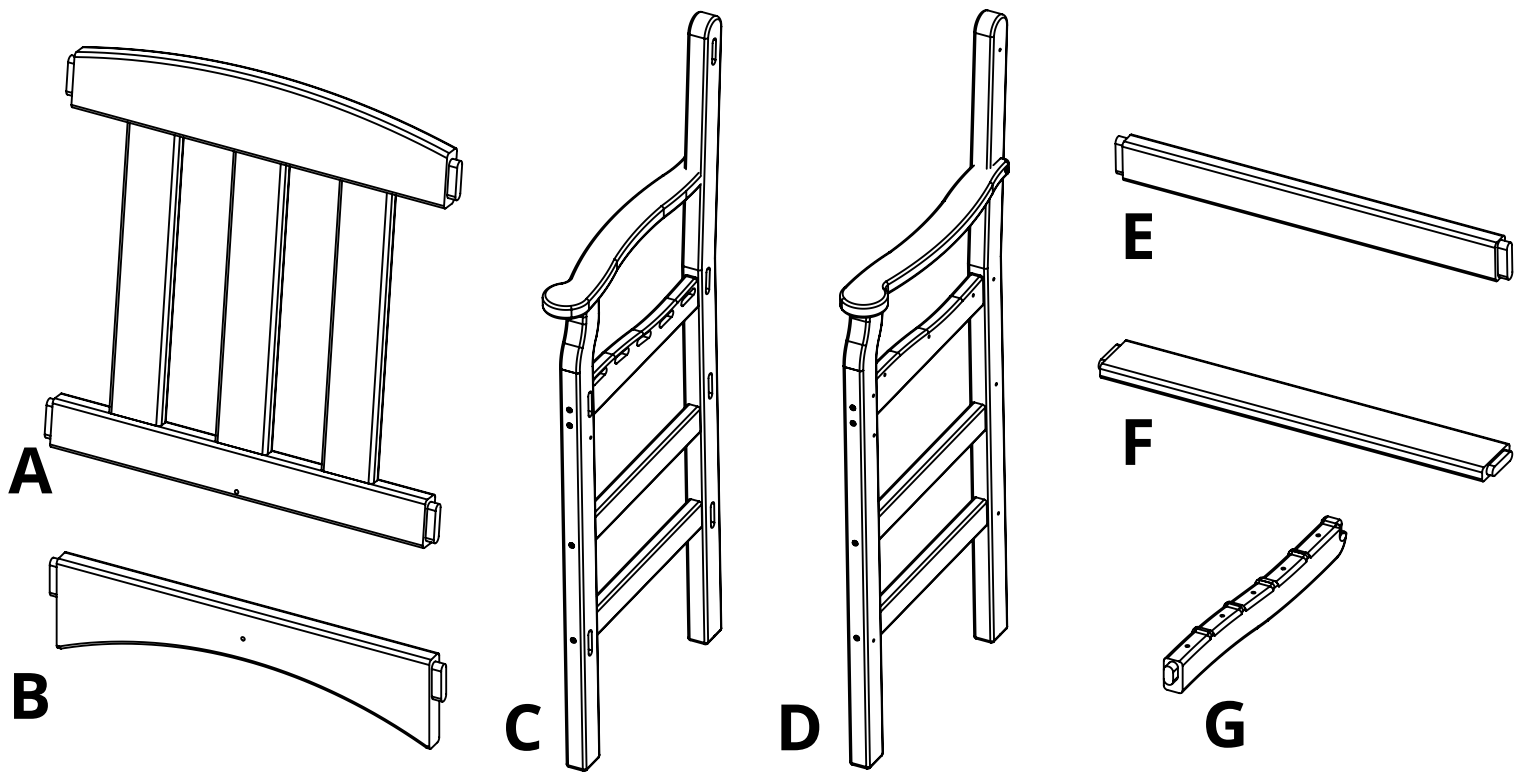

PARTS

PART	DESCRIPTION	PART NO.	QTY
A	BACK ASSEMBLY	SA-00157	1
B	FRONT RAIL	PRT-00293	1
C	LEFT SIDE ASSEMBLY	SA-00164	1
D	RIGHT SIDE ASSEMBLY	SA-00165	1
E	SPREADER	PRT-00304	3
F	STANDARD SEAT SLAT 21.25	SS-20.25	5
G	SEAT SUPPORT	PRT-00294	1

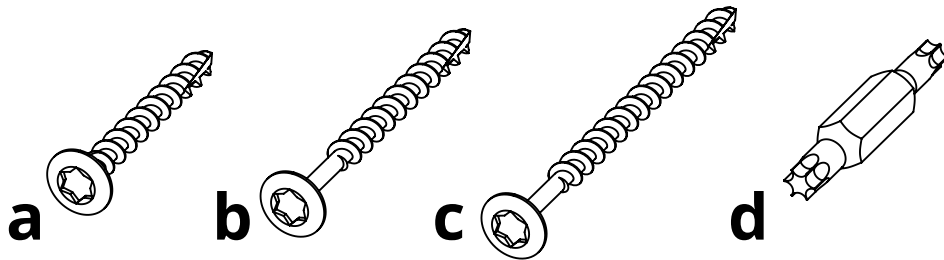

HARDWARE

PART	DESCRIPTION	PART NO.	QTY
a	#8 X 1-1/2" TORX SCREW	H-0000-S815	7
b	#8 X 2" TORX SCREW	H-0000-S82	5
c	#8 X 2-1/2" TORX SCREW	H-0000-S825	15
d	T20 & T25 TORX BIT	H-0000-CTD	1

Suggested Tools: Drill, Plastic Mallet

Please read entire instructions before beginning

1. Attach Parts A, E, F, & B to Part C using Hardware a on Parts F and Hardware c everywhere else

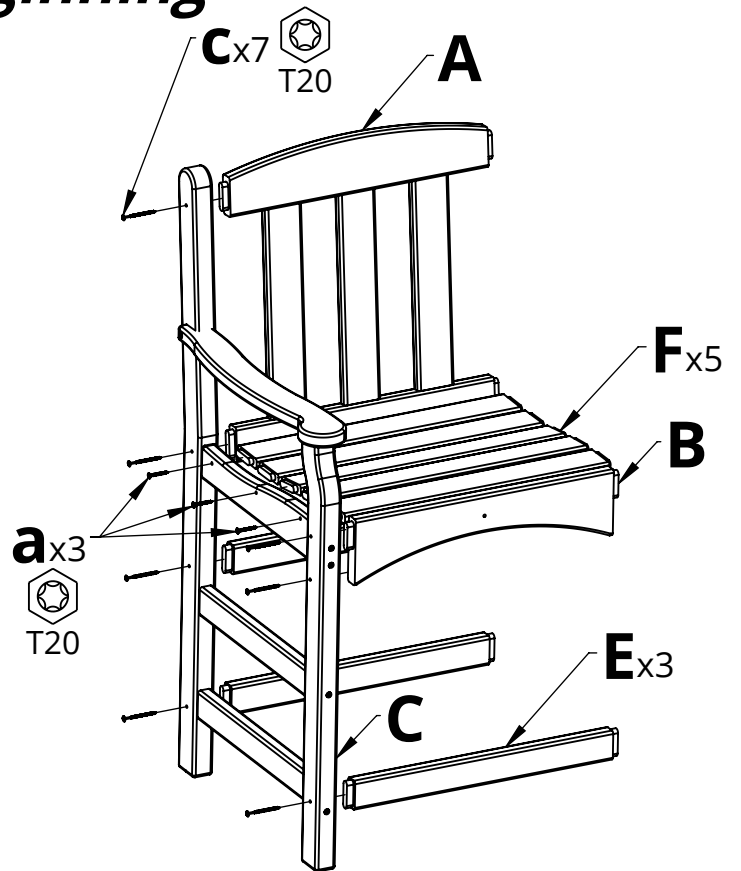

2. Attach Part D using the same hardware as Step 1

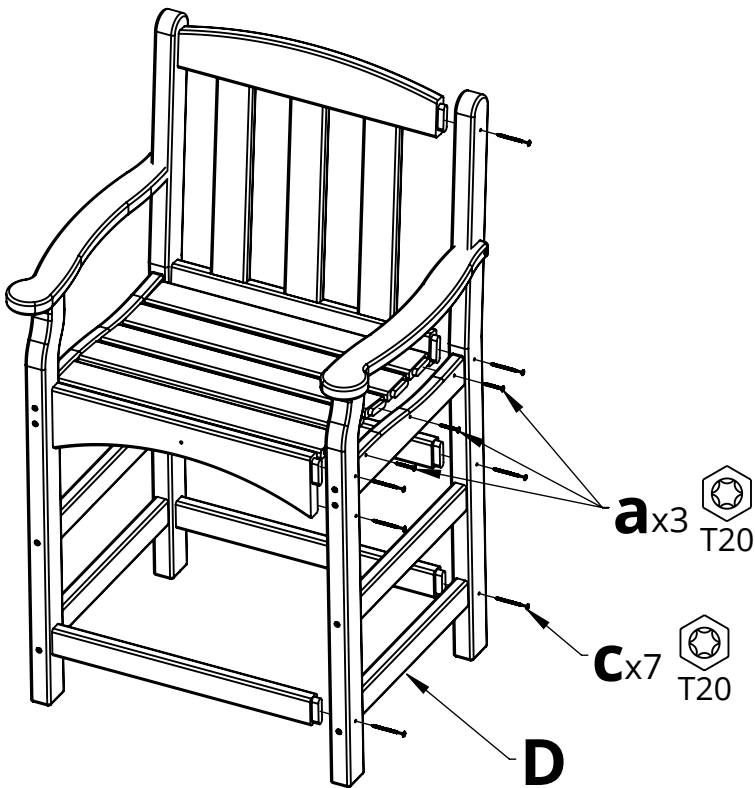

3. Attach Part G using the hardware shown

