

breezesta™

42"x 84" BAR TABLE
BH-0916

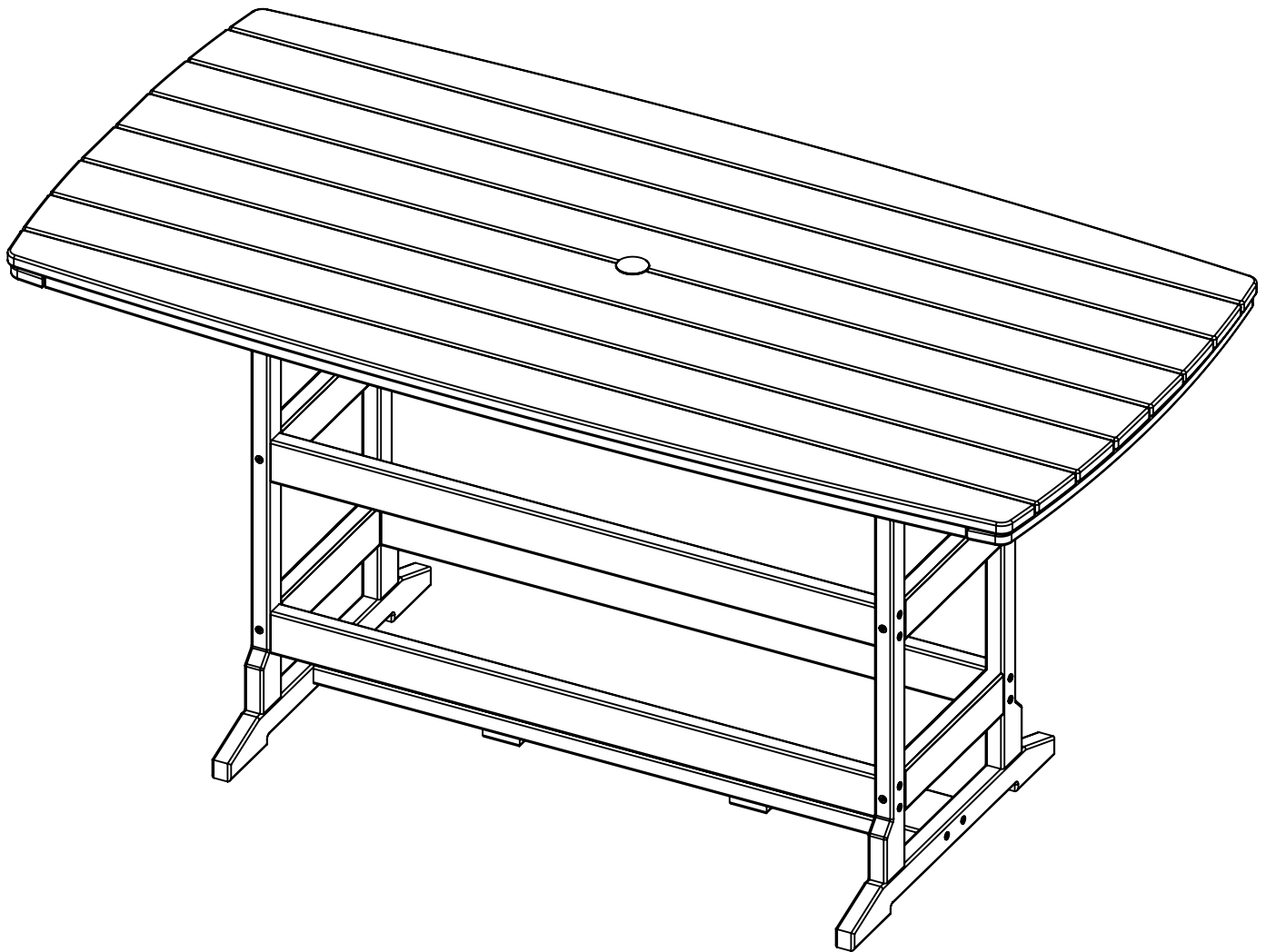

REV00-1/19

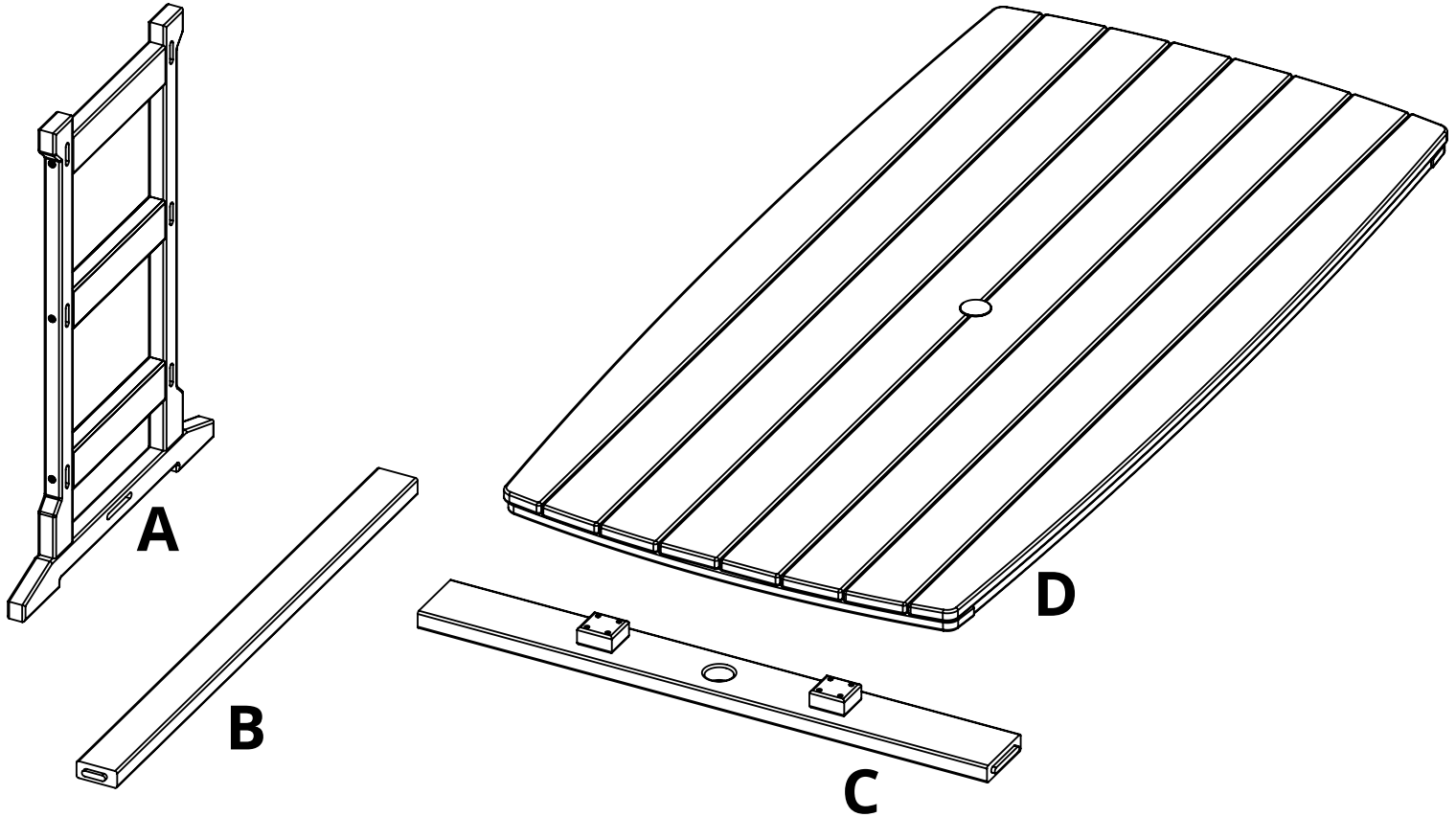

PARTS

PART	DESCRIPTION	PART NO.	QTY
A	SIDE ASSEMBLY	SA-00321	2
B	LONG SPREADER	PRT-00557	6
C	BASE SPREADER ASSEMBLY	SA-00335	1
D	TABLE TOP ASSEMBLY 42"x 84"	SA-00330	1

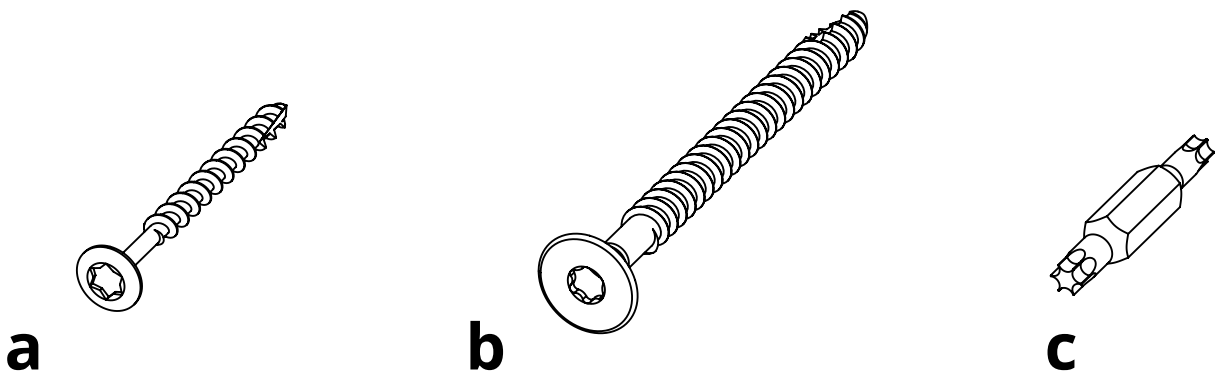

HARDWARE

PART	DESCRIPTION	PART NO.	QTY
a	#8 X 2" TORX SCREW	H-0000-S82	4
b	1/4-10 x 3" LAG	H-0000-S103	28
c	T20 & T25 TORX BIT	H-0000-CTD	1

Suggested Tools: Drill, Plastic Mallet

Please read entire instructions before beginning

- 1.** Attach Part B and Part C to Part A using Hardware b

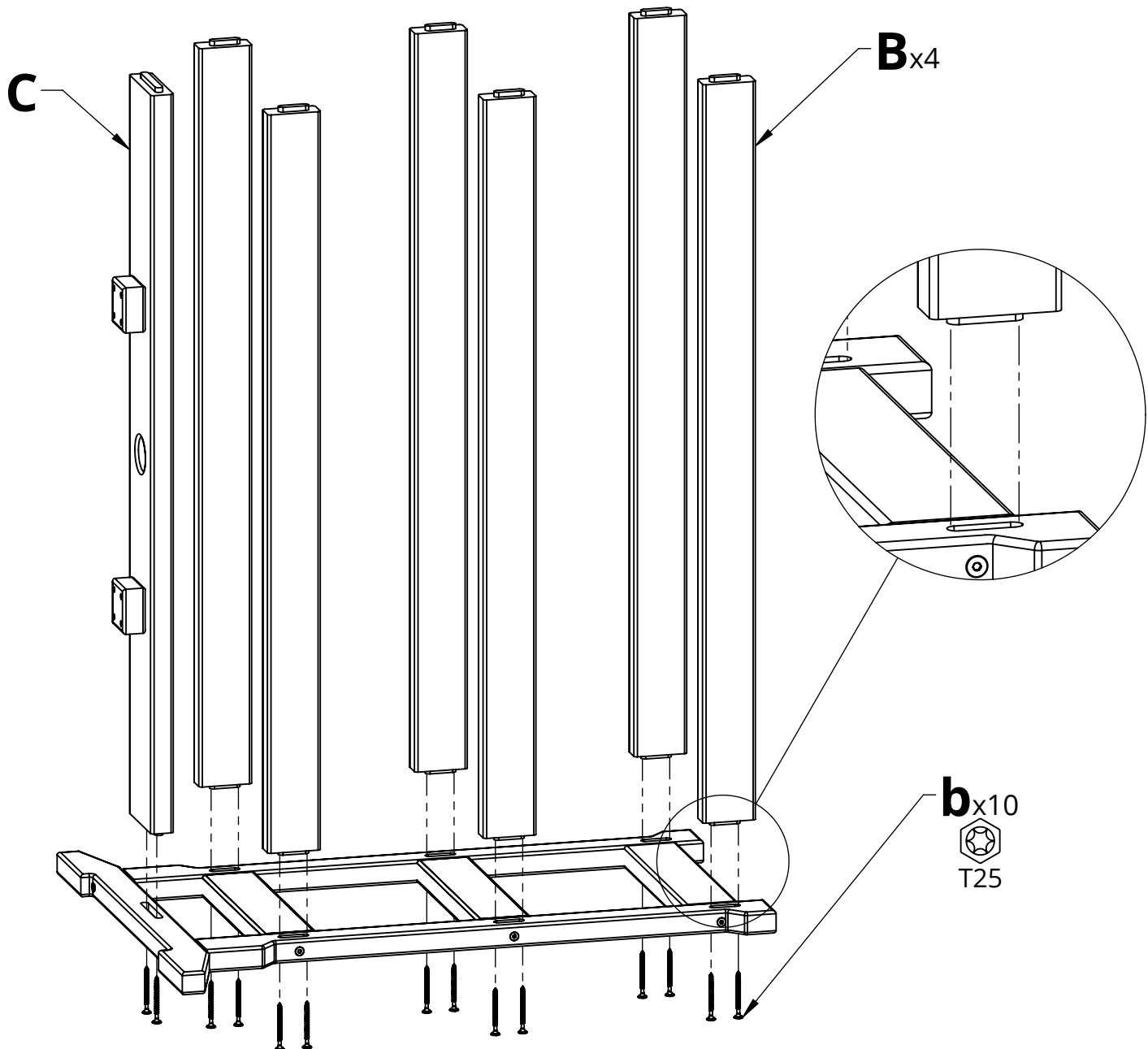

- 2.** Place second Part A on assembled piece from Step 1;
Repeat Step 1

3. Attach Part A onto Part D using Hardware a

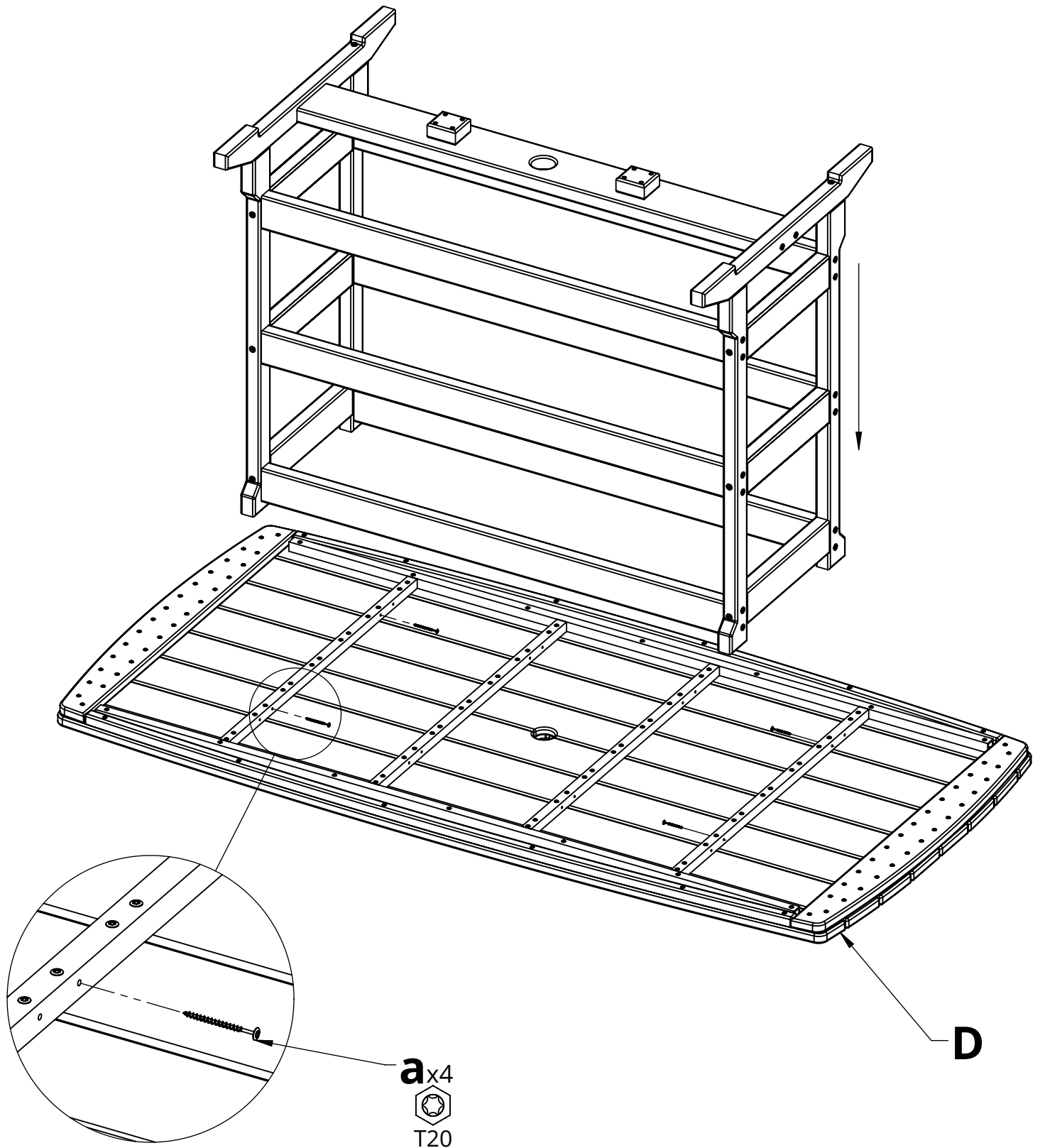

May be easier if assembled upside down