

breezesta™

CHAISE LOUNGE CHAIR W/WHEELS
CL-1300

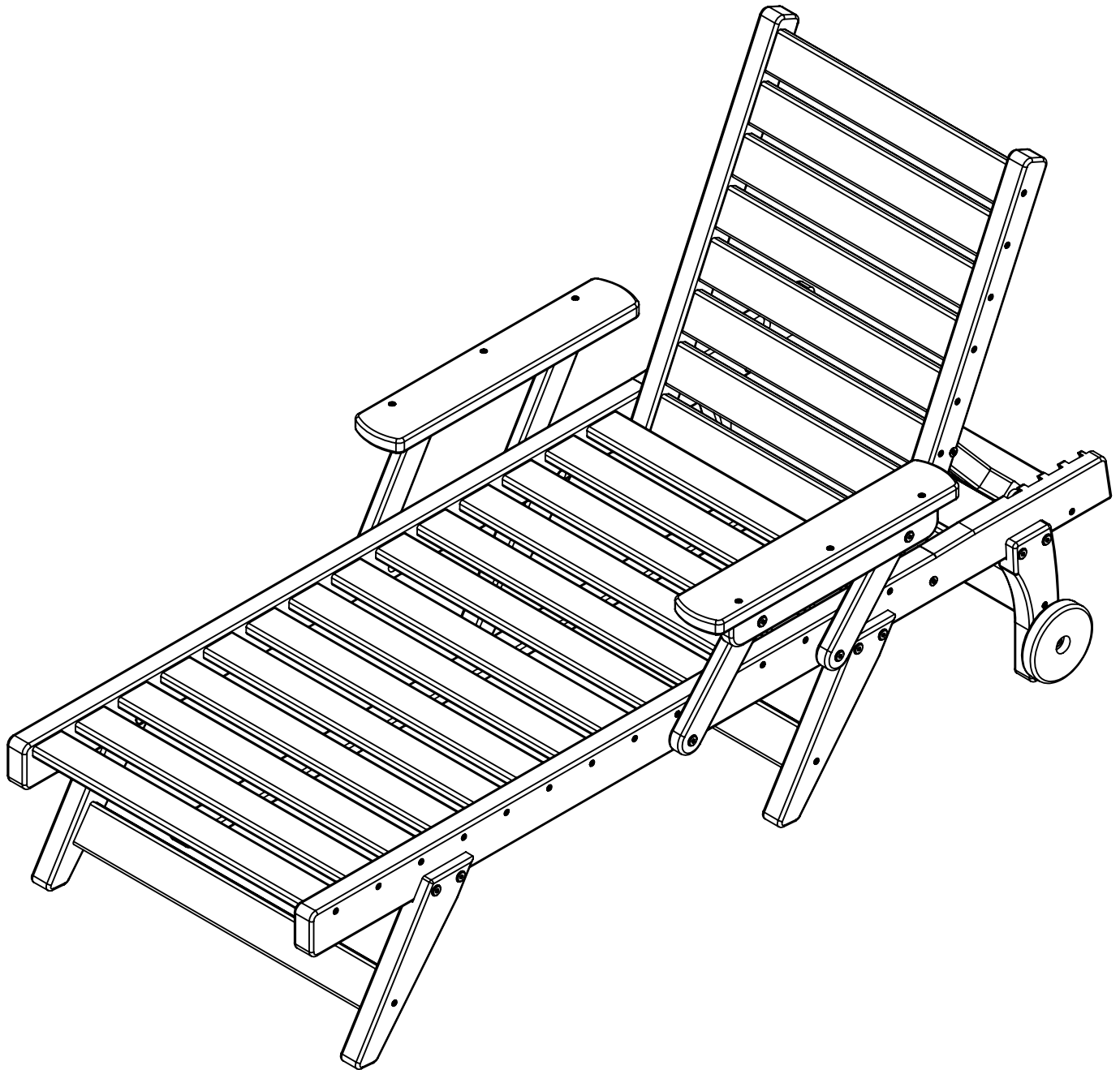

REV01-4/21

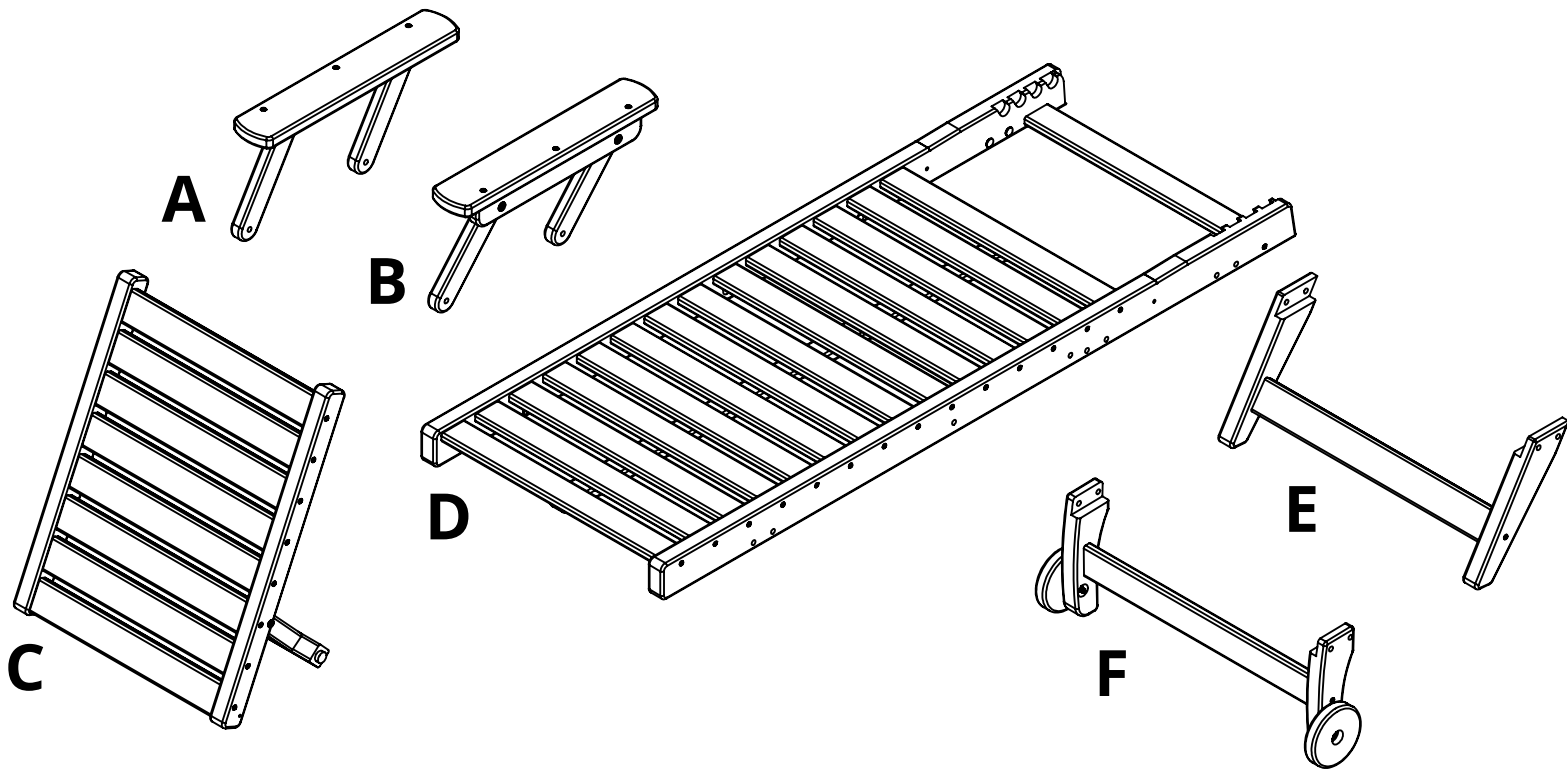

PARTS			
PART	DESCRIPTION	PART NO.	QTY
A	LEFT ARM ASSEMBLY	SA-00133	1
B	RIGHT ARM ASSEMBLY	SA-00134	1
C	SEAT BACK ASSEMBLY	SA-00132	1
D	SEAT ASSEMBLY	SA-00131	1
E	LEG ASSEMBLY	SA-00130	2
F	WHEEL KIT ASSEMBLY A	SA-00143	1

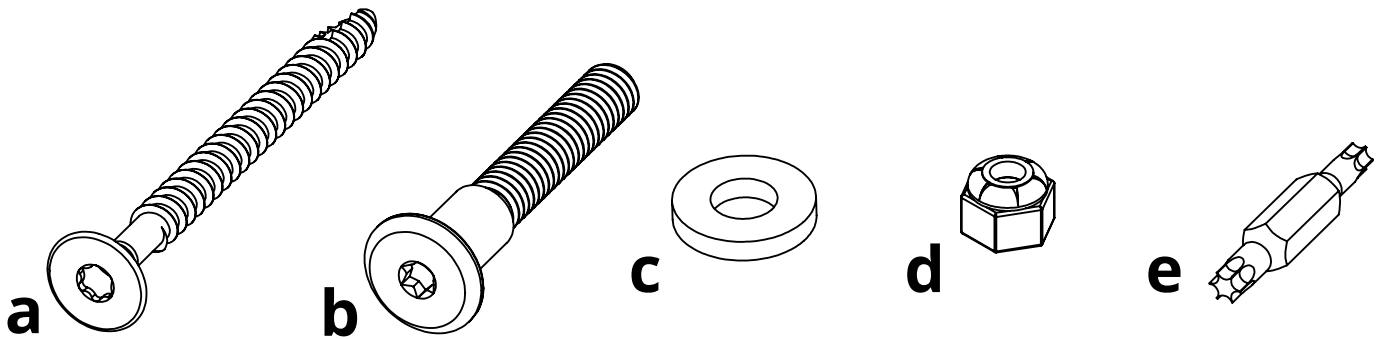

HARDWARE			
PART	DESCRIPTION	PART NO.	QTY
a	1/4"-10 X 3" LAG SCREW	H-0000-S103	2
b	5/16" X 2-1/8" CHAIR BOLT	H-0000-CB516218	16
c	LARGE WHITE NYLON WASHER	H-0000-LWNW	6
d	5/16" STAINLESS LOCK NUT	H-0000-LN516	4
e	T20 & T25 TORX BIT	H-0000-CTD	1

Suggested Tools: Drill, Plastic Mallet

Please read entire instructions before beginning

1. Place Parts E & F onto D as shown

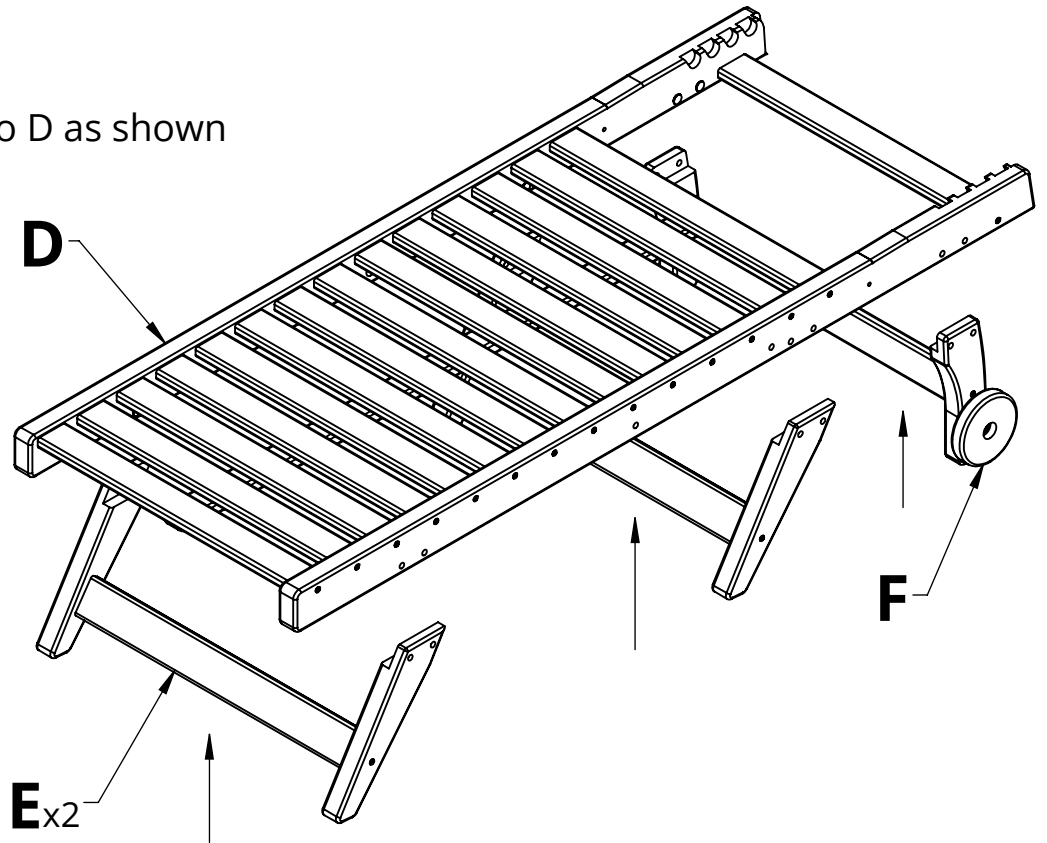

2. Attach Parts E & F to Part D using the hardware shown

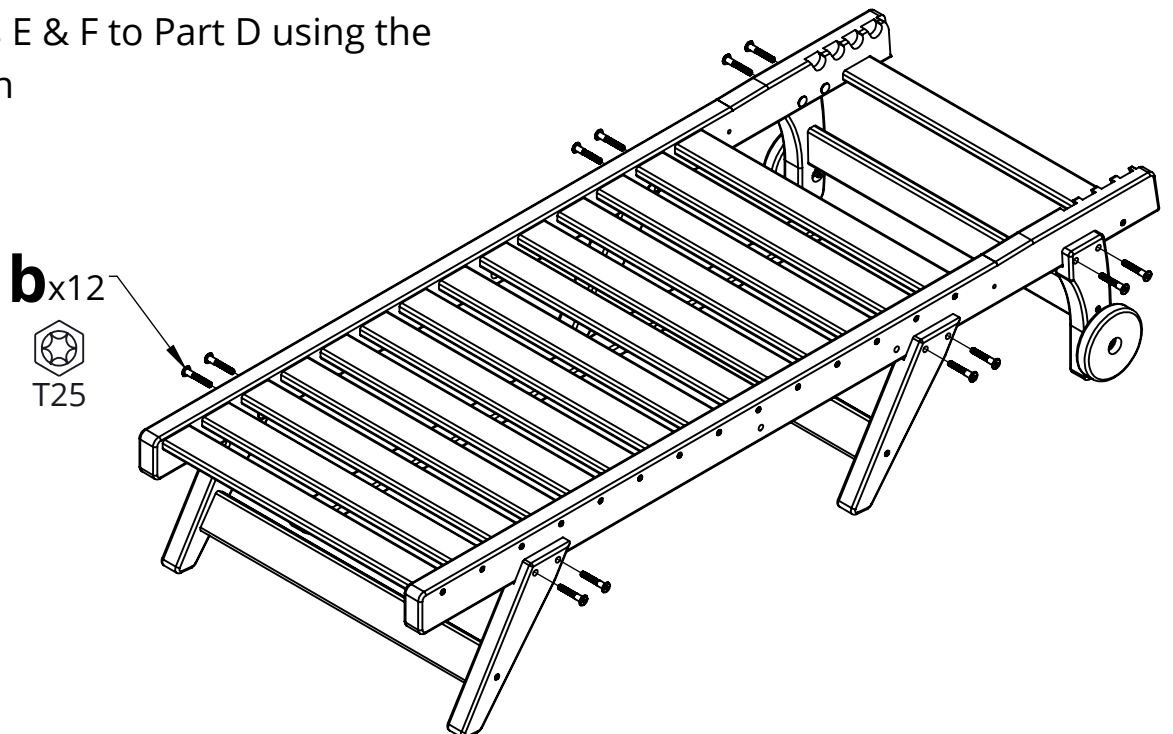

*Do not overtighten hardware 'a' this may cause adjuster bar misalignment

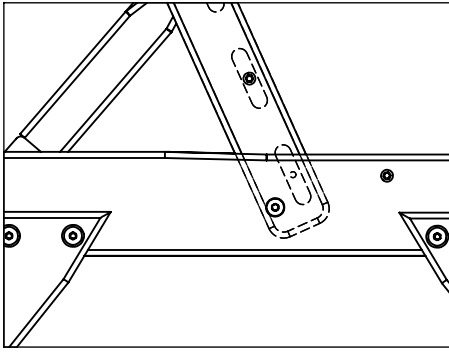

Side View

ax2



T25

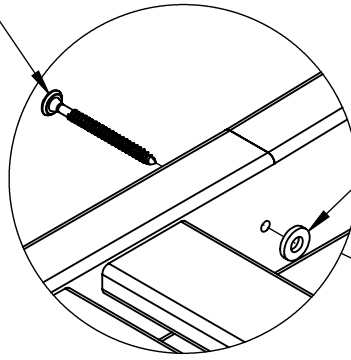

cx2

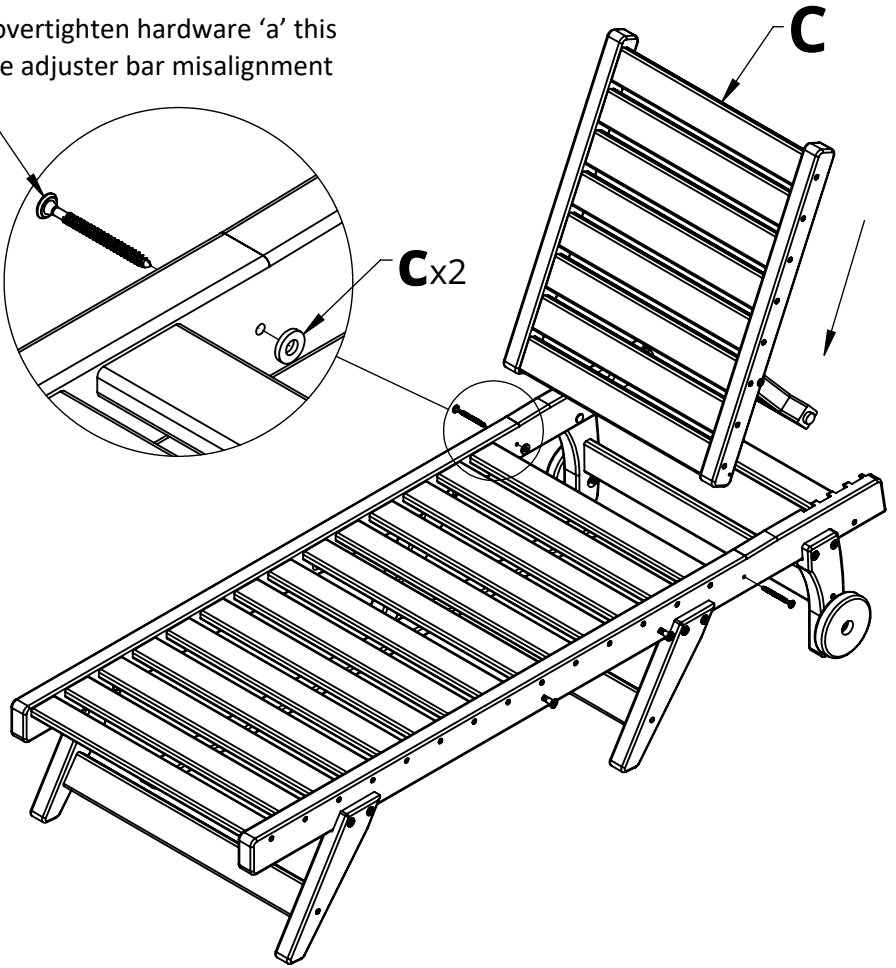

3. Drop Part C into place and secure it using Hardware a & c through the pre-drilled holes

Bottom View

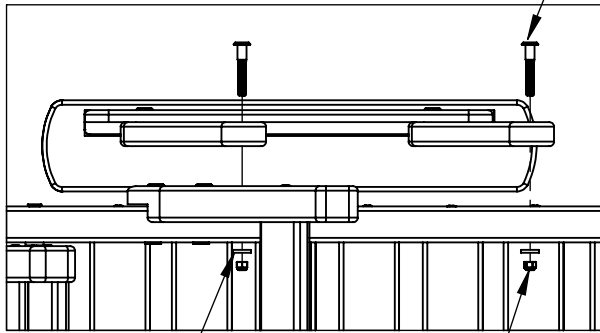

bx4



T25

cx4

dx4

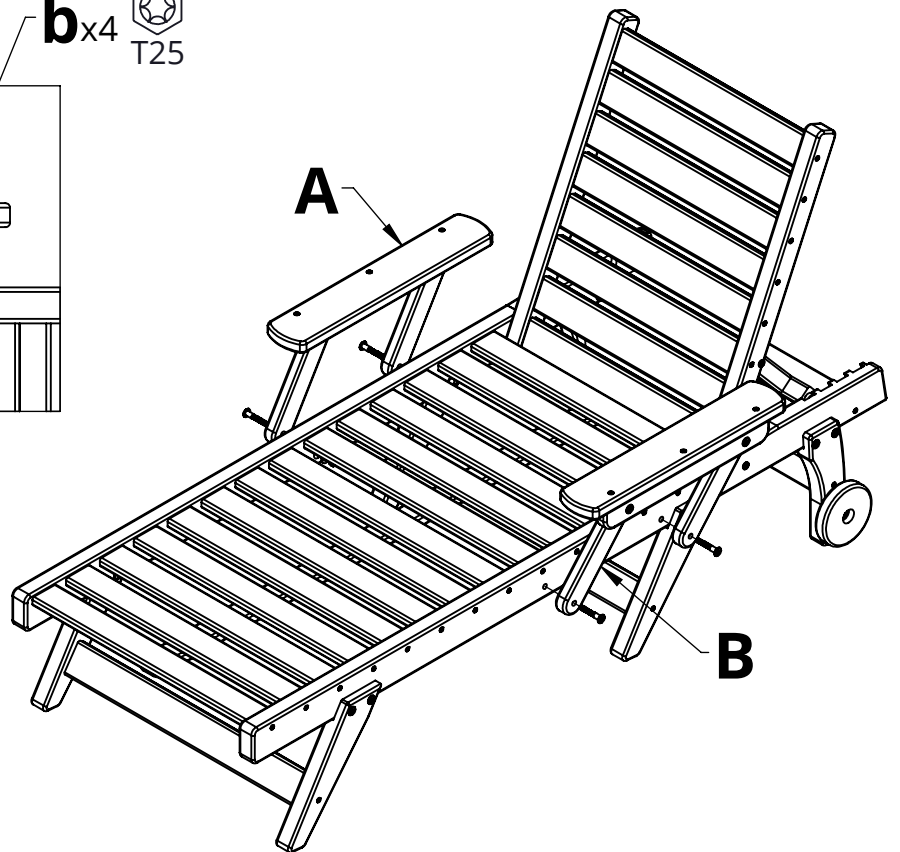

4. Place Parts A & B onto the assembly and attach it using the hardware as shown