

PARTS

PART	DESCRIPTION	PART NO.	QTY
A	LEFT LEG ASSEMBLY	SA-00021	2
B	RIGHT LEG ASSEMBLY	SA-00044	2
C	SWIVEL SUPPORT ASSEMBLY	SA-00085	1
D	SEAT ASSEMBLY	SA-00089	1
E	ARM CONNECTOR ASSEMBLY	SA-00086	2
F	UNDER ARM SUPPORT	PRT-00146	2
G	LEFT ARM ASSEMBLY	SA-00087	1
H	RIGHT ARM ASSEMBLY	SA-00088	1
I	COASTAL/BB SEAT SLAT	SS-17.437	2
J	BASE RAIL	PRT-00174	2
K	FOOT REST	PRT-00168	2
L	BACK ASSEMBLY	SA-00069	1

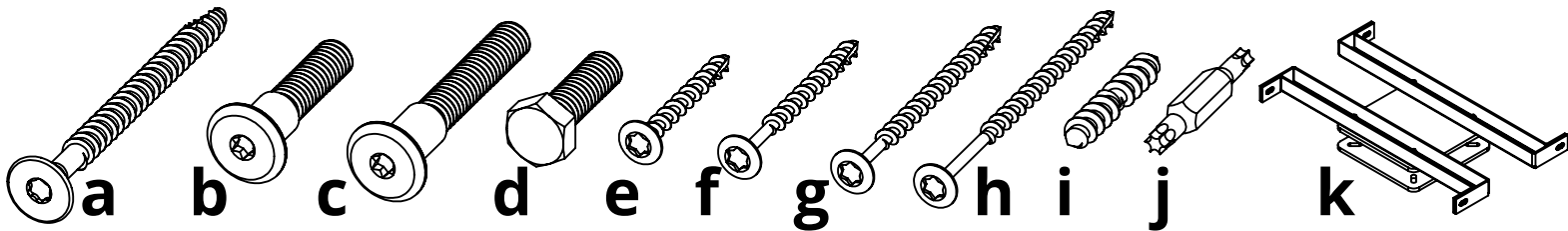

HARDWARE

PART	DESCRIPTION	PART NO.	QTY
a	1/4"-10 X 3" LAG SCREW	H-0000-S103	4
b	5/16" X 1-1/2" CHAIR BOLT	H-0000-CB51615	2
c	5/16" X 2-1/8" CHAIR BOLT	H-0000-CB516218	20
d	1" HEX BOLT 5/16" DIA	H-0000-HB1	4
e	#8 X 1-1/2" TORX SCREW	H-0000-S815	4
f	#8 X 2" TORX SCREW	H-0000-S82	2
g	#8 X 2-1/2" TORX SCREW	H-0000-S825	4
h	#8 X 3" TORX SCREW	H-0000-S83	8
i	DOUBLE SCREW	H-0000-DS	2
j	T20 & T25 TORX BIT	H-0000-CTD	1
k	COASTAL SWIVEL ASSEMBLY-GEN 3	H-0000-SAC3	1

Suggested Tools: Drill, Plastic Mallet, 1/2" Socket Wrench

Please read entire instructions before beginning

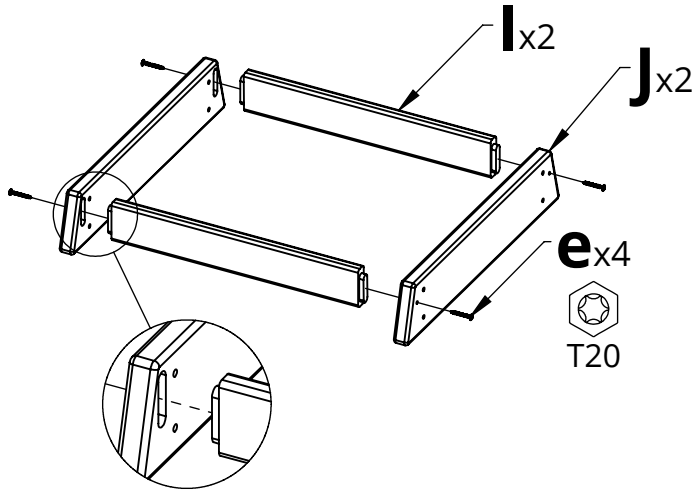

1. Connect Parts I & J together using Hardware e

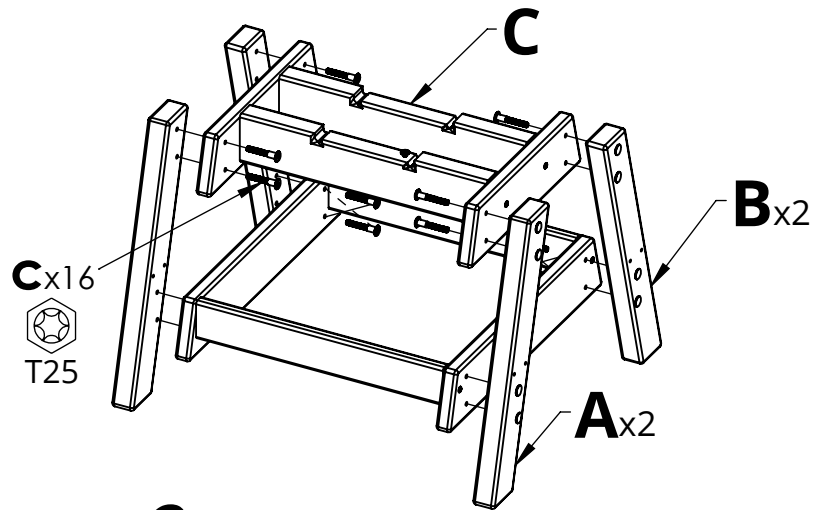

2. Connect Parts A & B to Part C & previous assembly using Hardware c

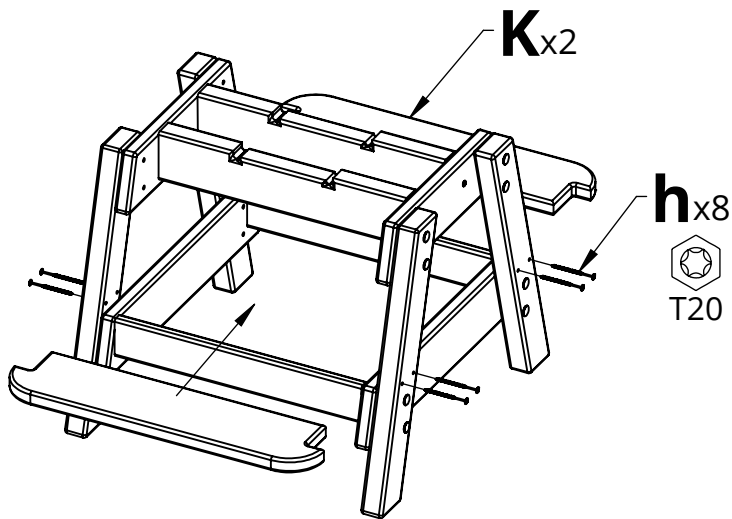

3. Attach Part K to the previous assembly using Hardware h

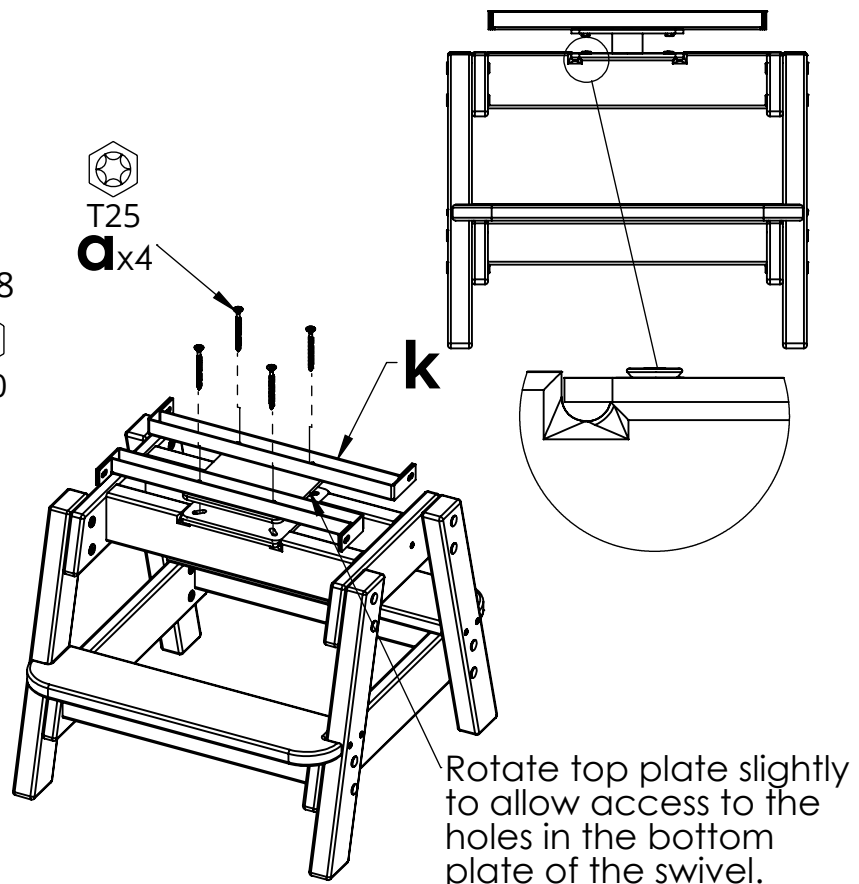

4. Attach Hardware k to the previous assembly using Hardware a

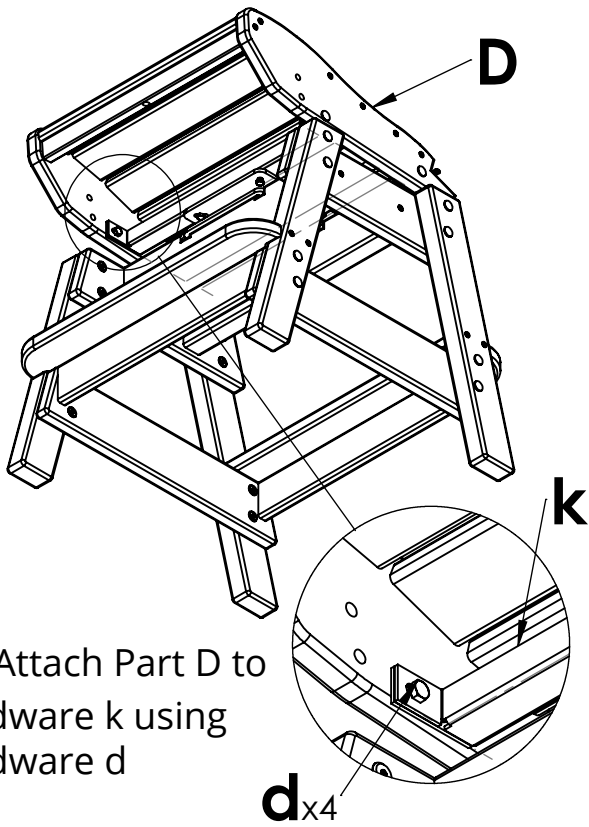

5. Attach Part D to Hardware k using Hardware d

d_{x4}

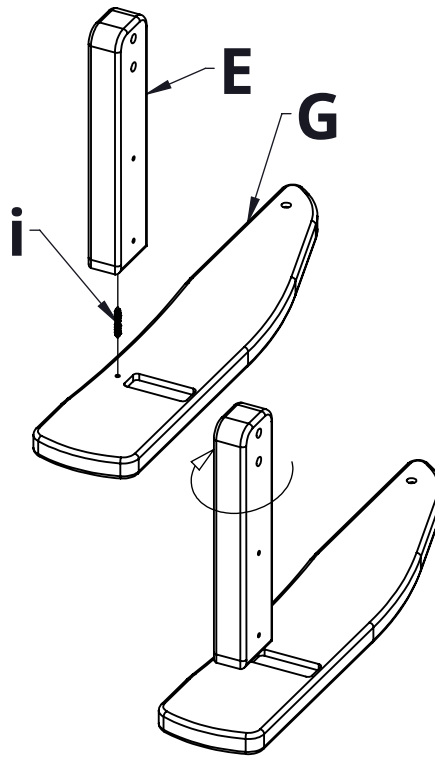

6. Attach Part E to Part G using Hardware i

7. Rotate Part E clockwise until tight in the orientation shown

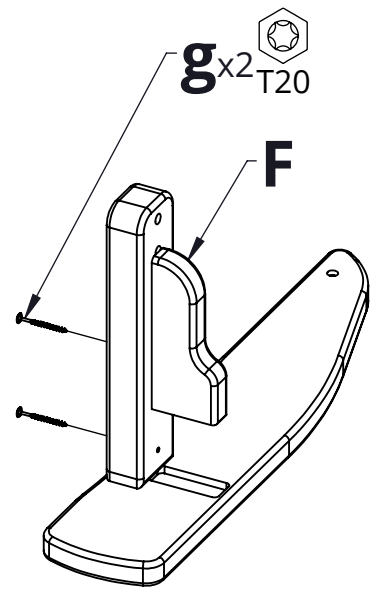

8. Place Part F into the pre cut slot and attach with Hardware g

9. Repeat steps 6-8 for Parts H, E, & F

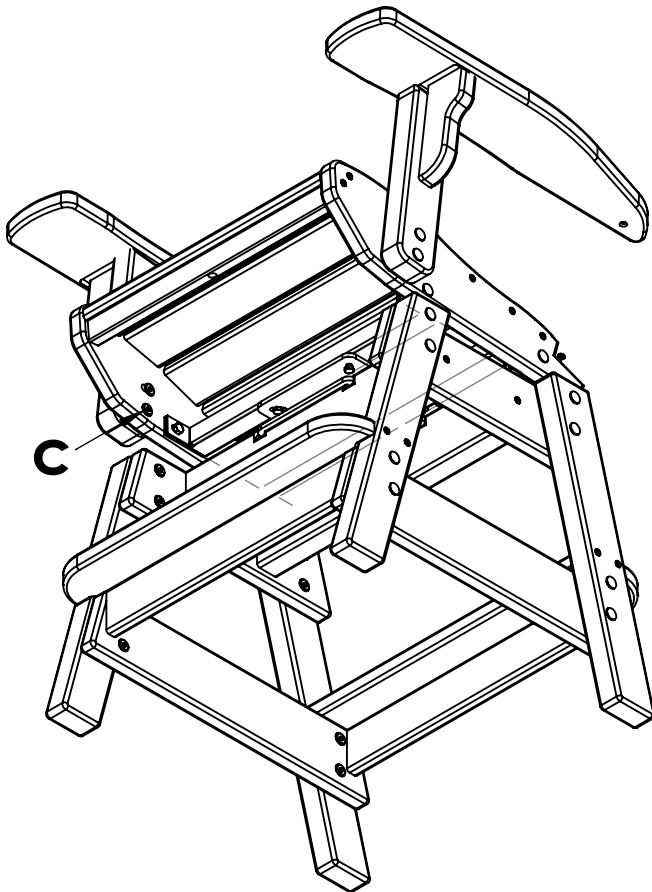

10. Attach the two arm assemblies from steps 6-9 to the seat base using hardware c

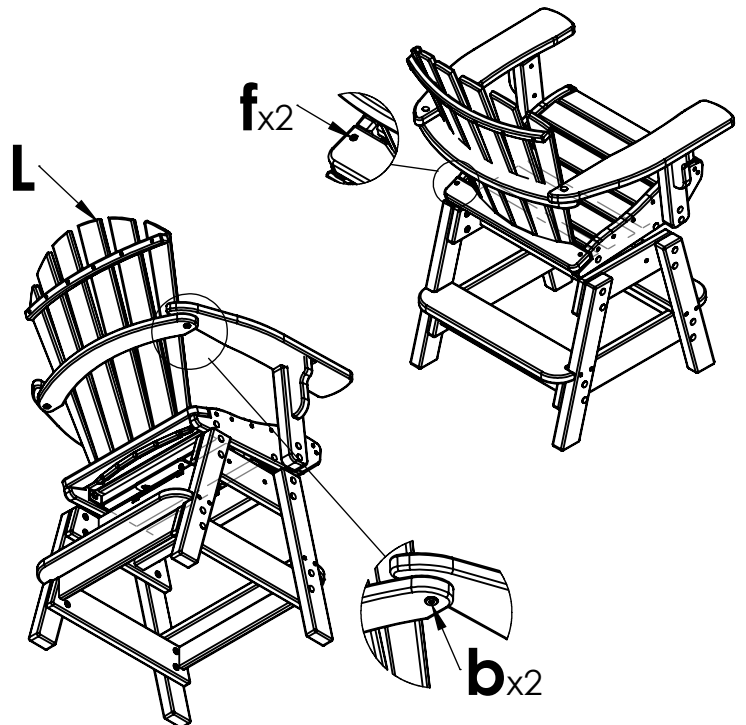

11. Attach Back Assembly L to the seat base using hardware f. Attach the Back Assembly center support to each arm using hardware b