

breezesta™

**CONTEMPORARY ACCENT TABLE**  
**CT-2101**

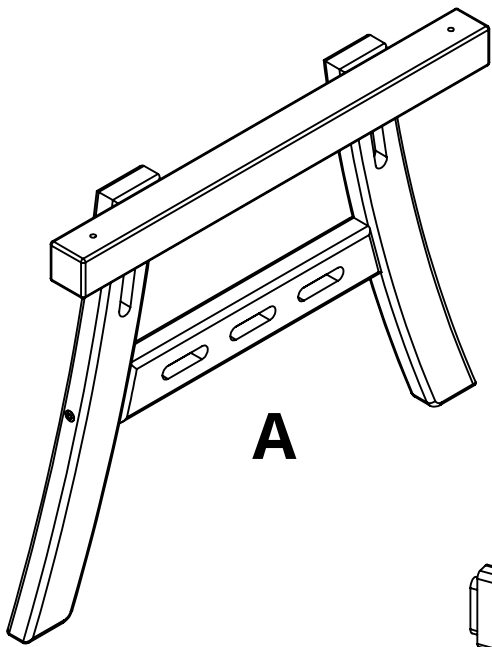

REV03-7/20



**A**

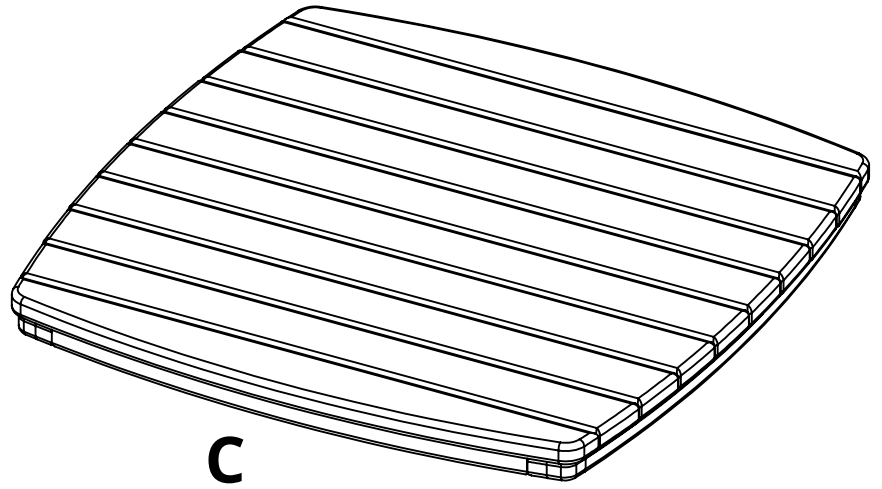

**C**

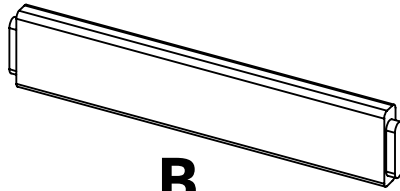

**B**

### PARTS

PART	DESCRIPTION	PART NO.	QTY
A	SIDE ASSEMBLY	SA-00249	2
B	BB FOOT REST SPREADER	SS-13	5
C	TABLE TOP ASSEMBLY	SA-00250	1

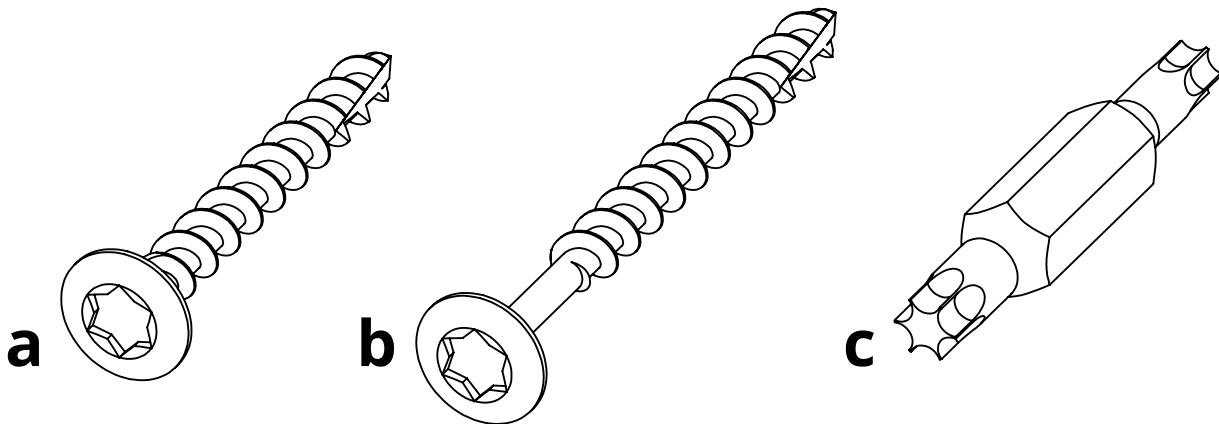

**a**

**b**

**c**

### HARDWARE

PART	DESCRIPTION	PART NO.	QTY
a	#8 X 1-1/2" TORX SCREW	H-0000-S815	10
b	#8 X 2" TORX SCREW	H-0000-S82	4
c	T20 & T25 TORX BIT	H-0000-CTD	1

**Suggested Tools:** Drill, Plastic Mallet

# *Please read entire instructions before beginning*

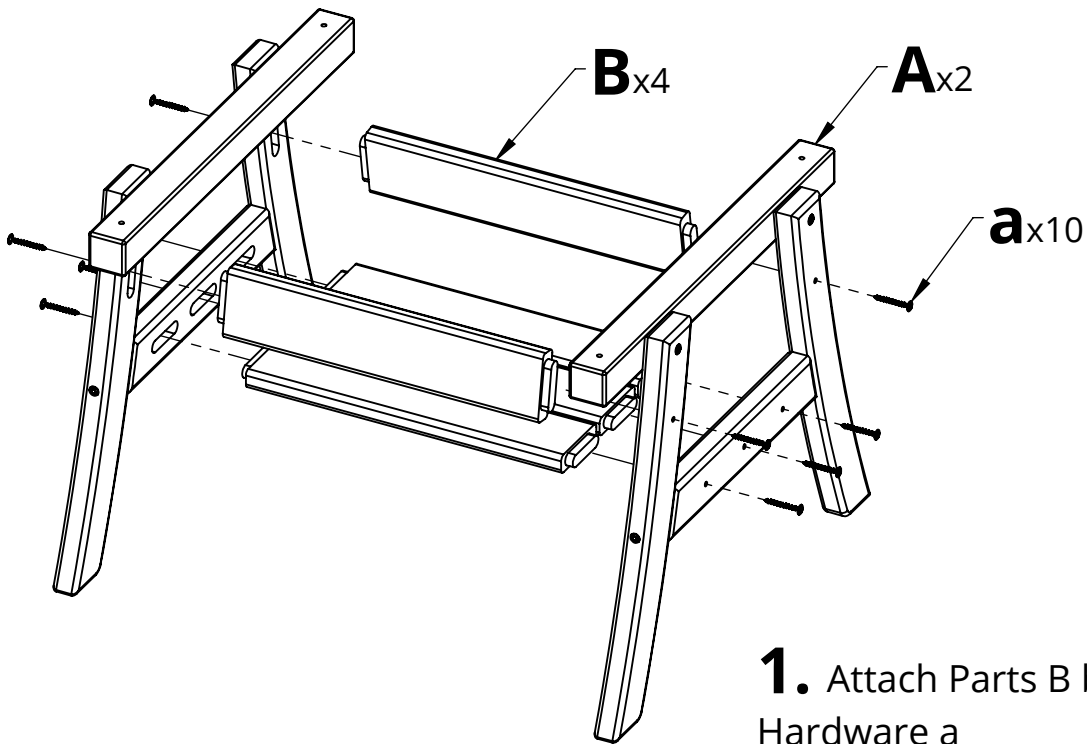

**2.** Connect Part C to the previous assembly using Hardware b

