

breezesta™

PIEDMONT DINING CAPTAINS CHAIR
PT-0506

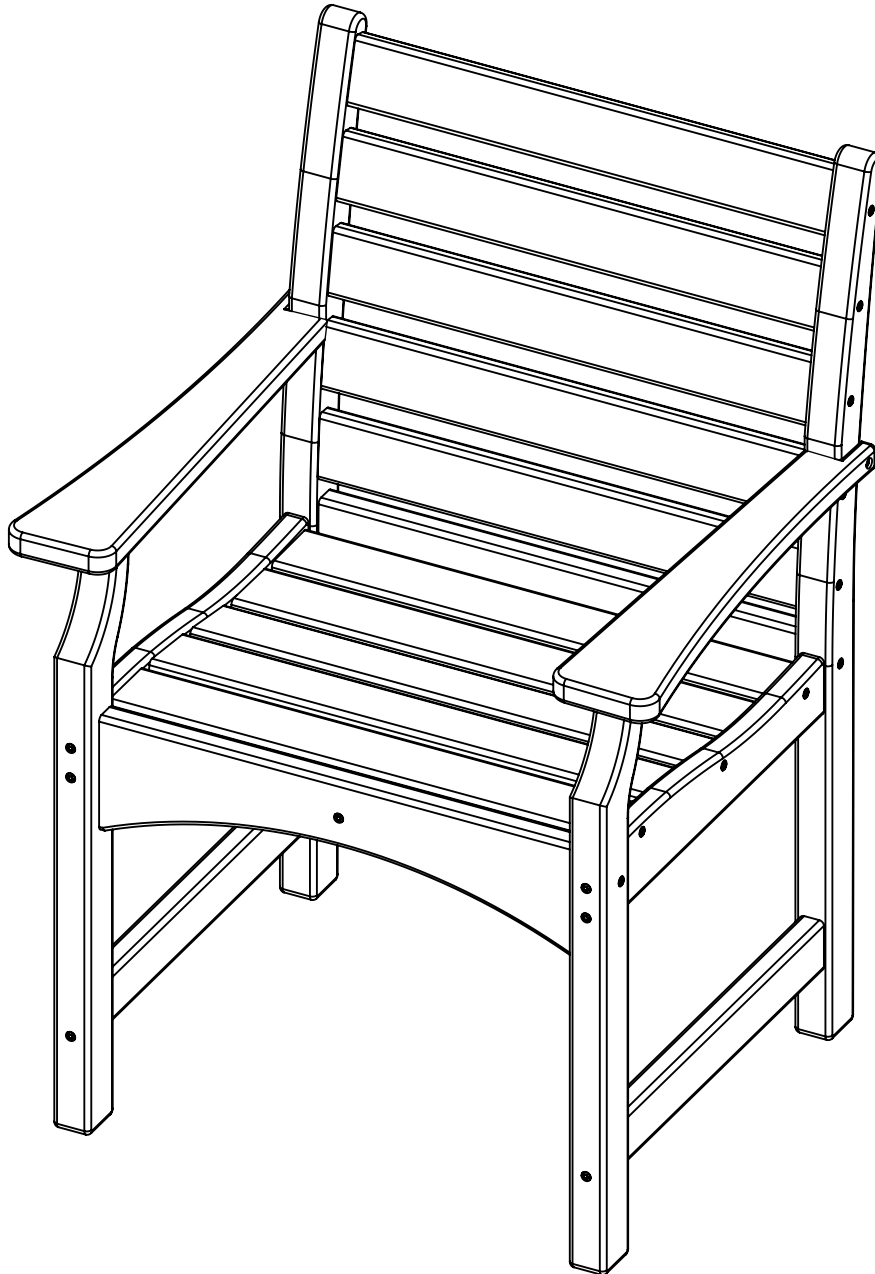

REV00-1/19

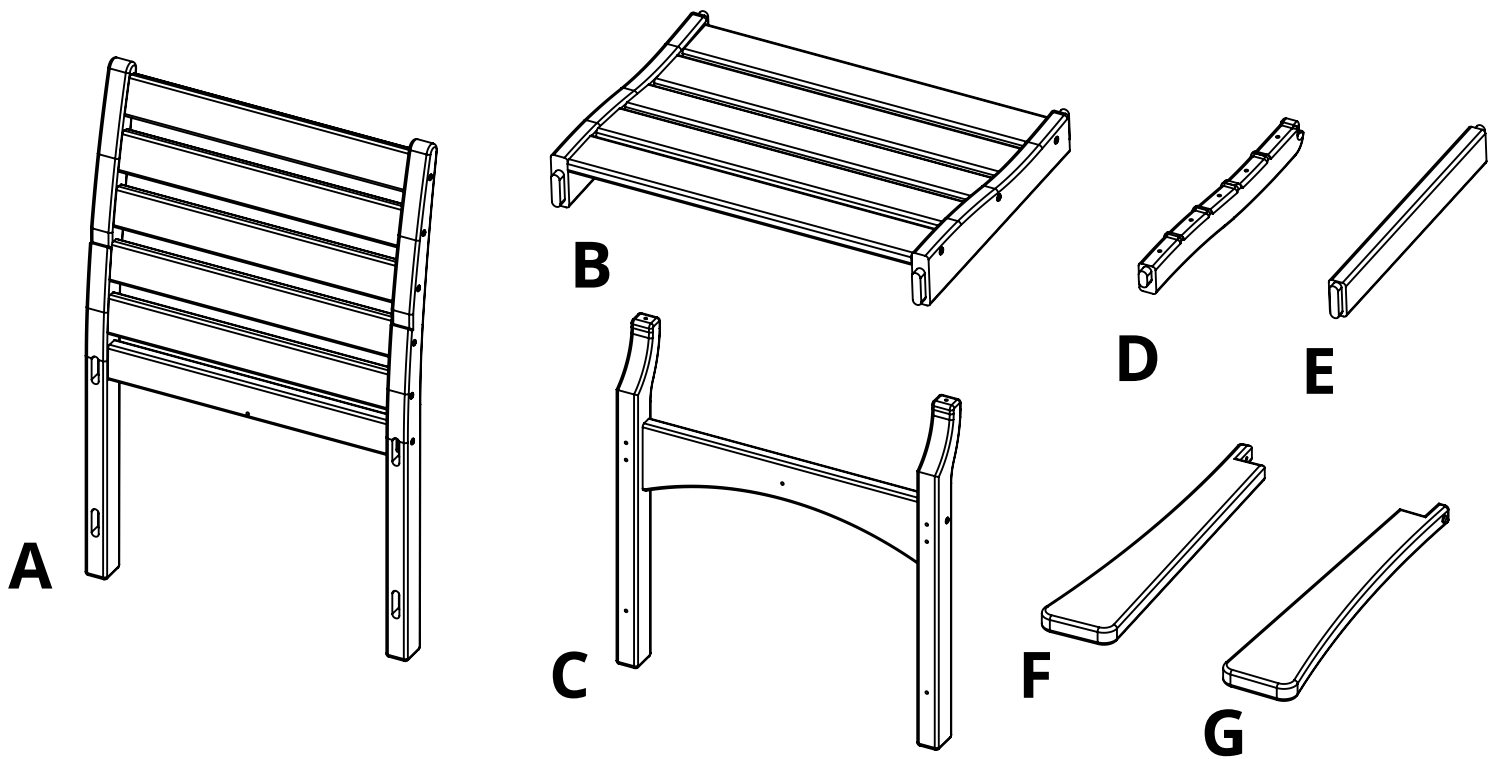

PARTS			
PART	DESCRIPTION	PART NO.	QTY
A	BACK ASSEMBLY	SA-00216	1
B	SEAT ASSEMBLY	SA-00207	1
C	FRONT ASSEMBLY	SA-00215	1
D	SEAT SUPPORT	PRT00294	1
E	BASE SPREADER	PRT-00287	2
F	LEFT ARM	PRT-00392	1
G	RIGHT ARM	PRT-00393	1

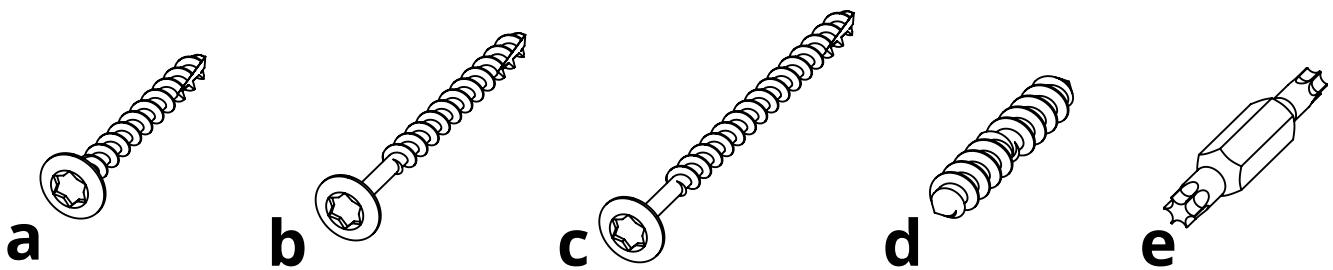

HARDWARE			
PART	DESCRIPTION	PART NO.	QTY
a	#8 X 1-1/2" TORX SCREW	H-0000-S815	3
b	#8 X 2" TORX SCREW	H-0000-S82	5
c	#8 X 2-1/2" TORX SCREW	H-0000-S825	13
d	DOUBLE SCREW	H-0000-DS	2
e	T20 & T25 TORX BIT	H-0000-CTD	1

Suggested Tools: Drill, Plastic Mallet

Please read entire instructions before beginning

1. Place Parts E & B into A as shown

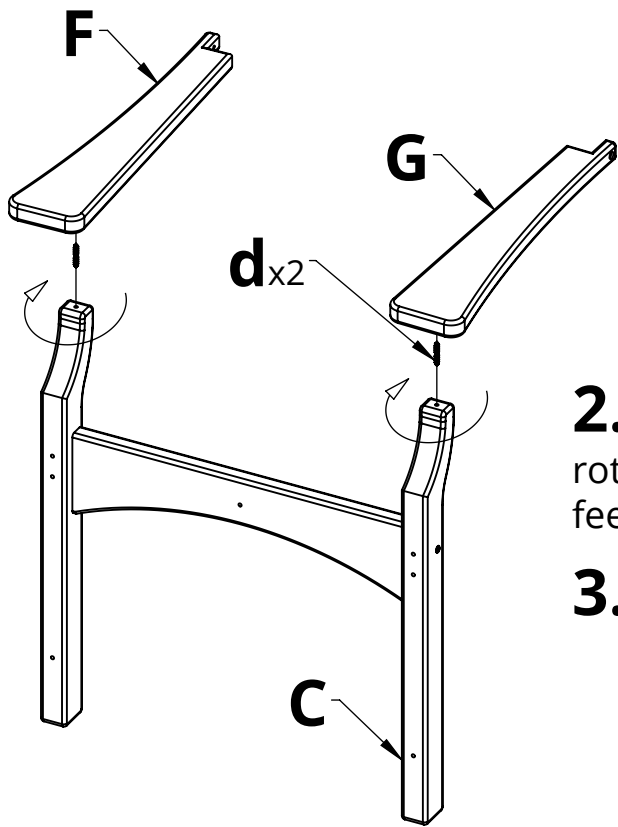
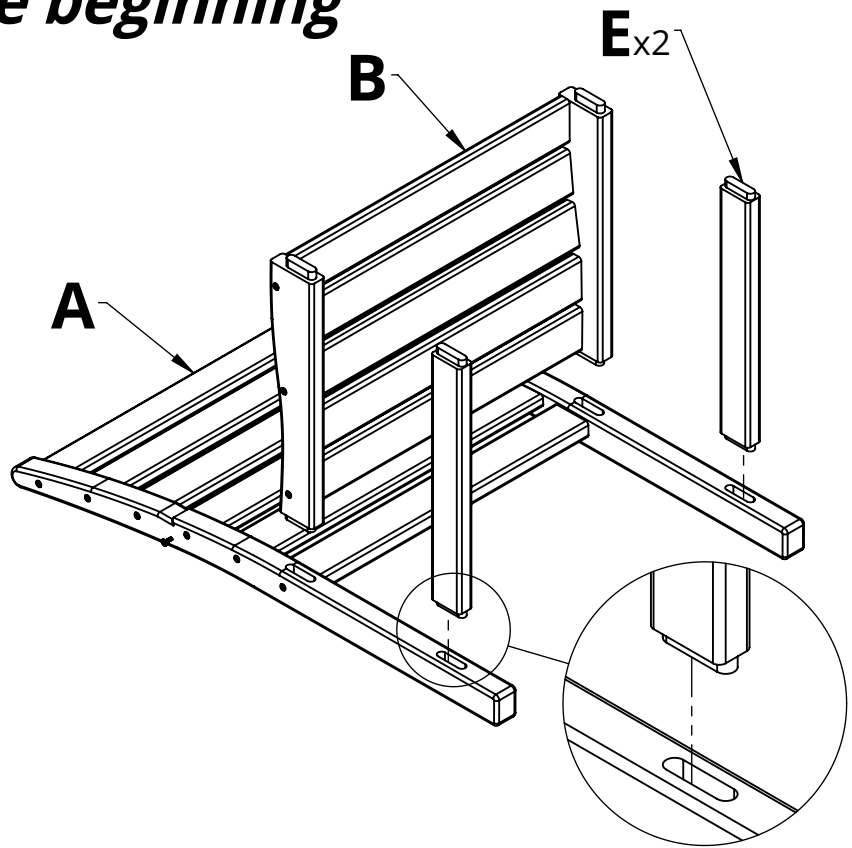

2. Connect Part G to C with Hardware d by rotating Part G clockwise until the connection feels tight

3. Repeat Step 3 for Part F

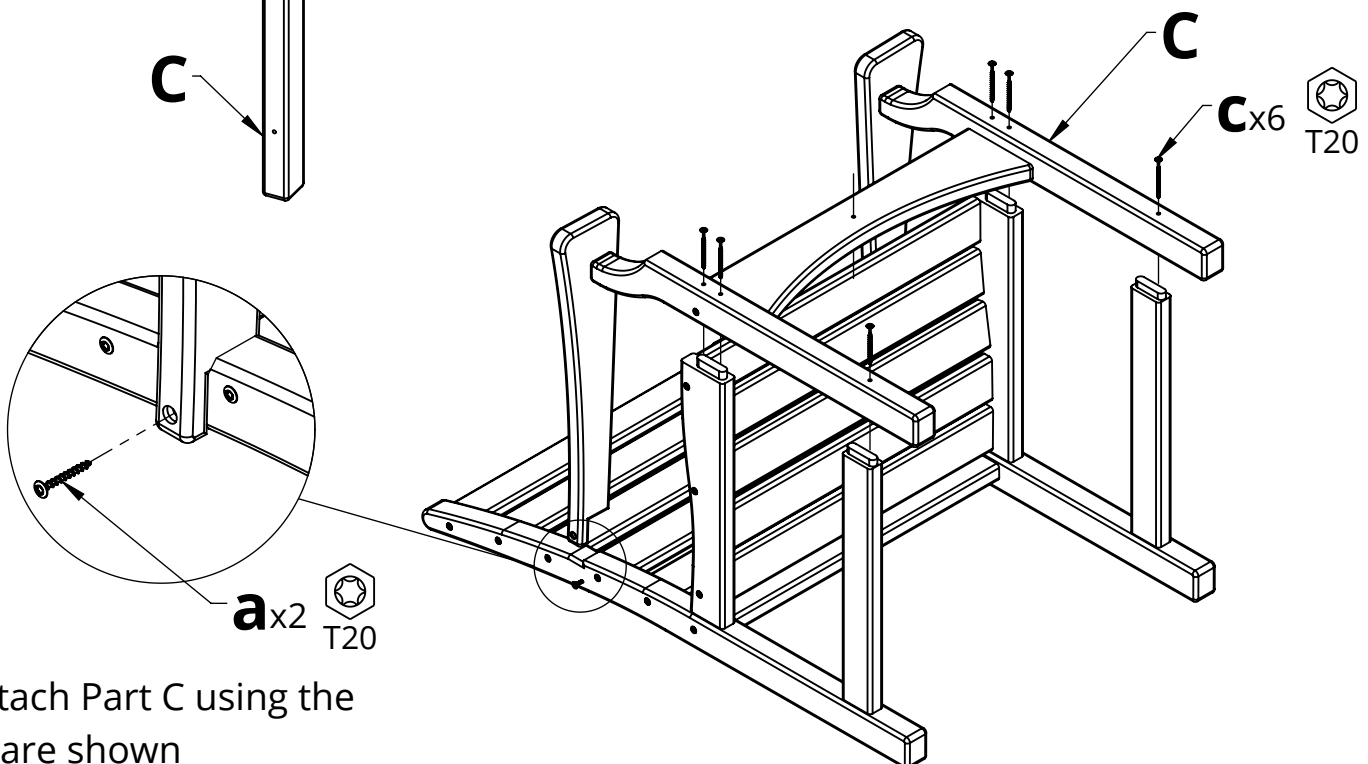

4. Attach Part C using the hardware shown

5. Turn the assembly over & attach the hardware shown

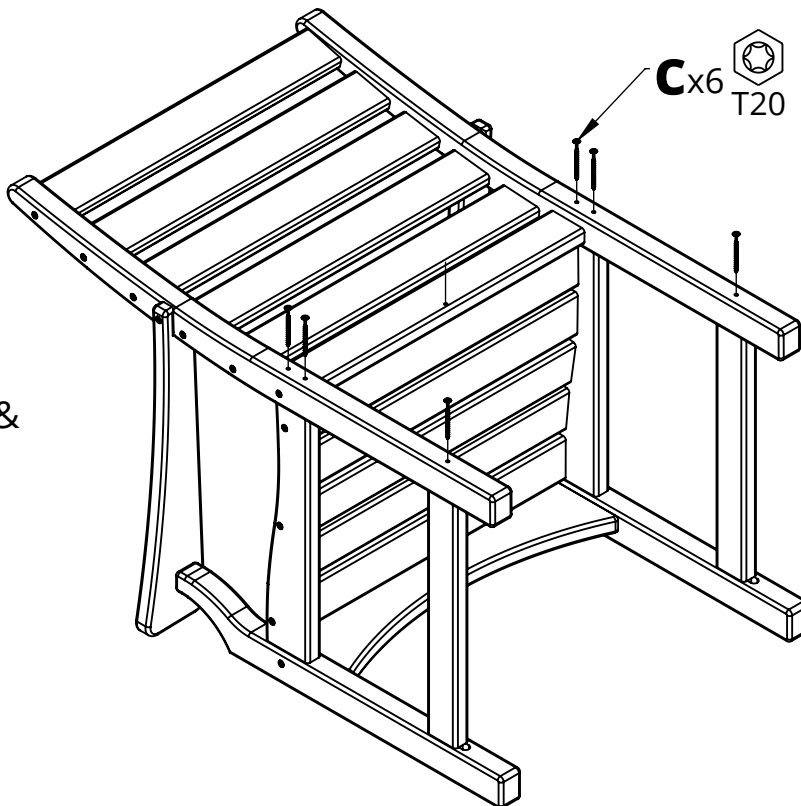

6. Connect Part D to the center, underside of Part B as shown

