

breezesta™

PIEDMONT COUNTER SIDE CHAIR
PT-0510

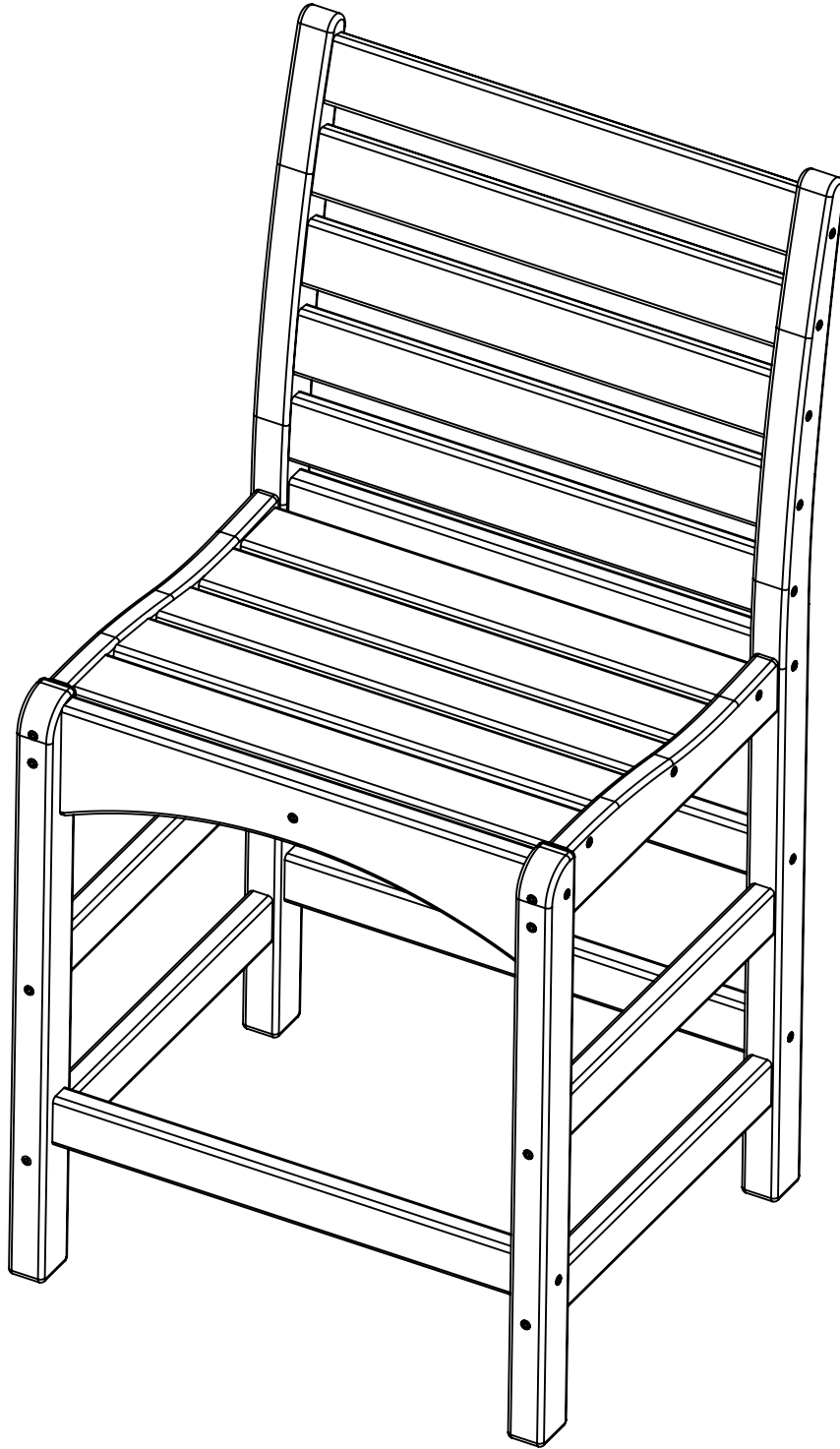

REV00-1/19

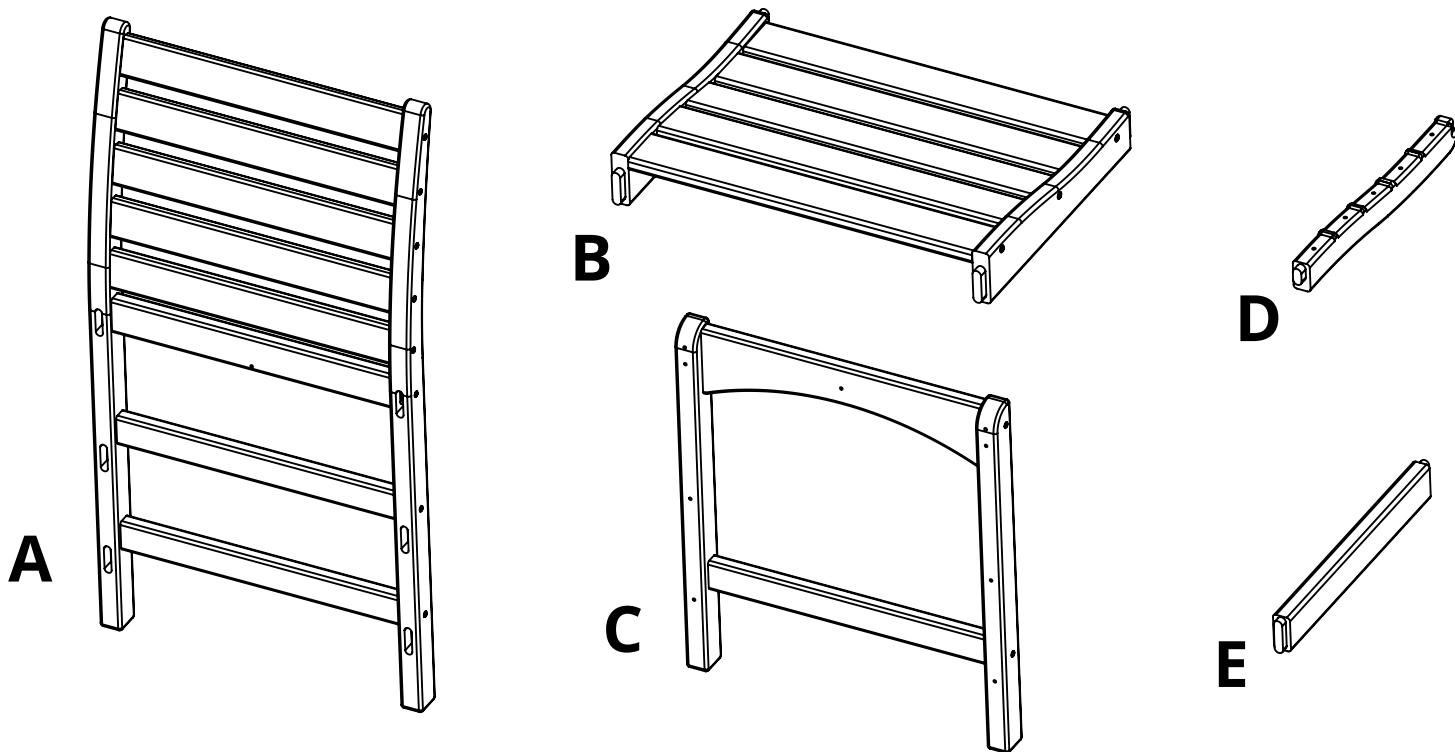

PARTS			
PART	DESCRIPTION	PART NO.	QTY
A	BACK ASSEMBLY	SA-00211	1
B	SEAT ASSEMBLY	SA-00207	1
C	FRONT ASSEMBLY	SA-00210	1
D	SEAT SUPPORT	PRT-00294	1
E	BASE SPREADER	PRT-00287	4

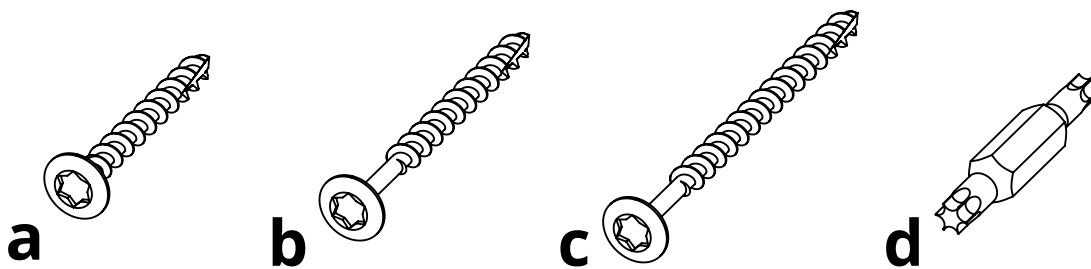

HARDWARE			
PART	DESCRIPTION	PART NO.	QTY
a	#8 X 1-1/2" TORX SCREW	H-0000-S815	1
b	#8 X 2" TORX SCREW	H-0000-S82	5
c	#8 X 2-1/2" TORX SCREW	H-0000-S825	17
e	T20 & T25 TORX BIT	H-0000-CTD	1

Suggested Tools: Drill, Plastic Mallet

Please read entire instructions before beginning

1. Place Parts E & B into A as shown

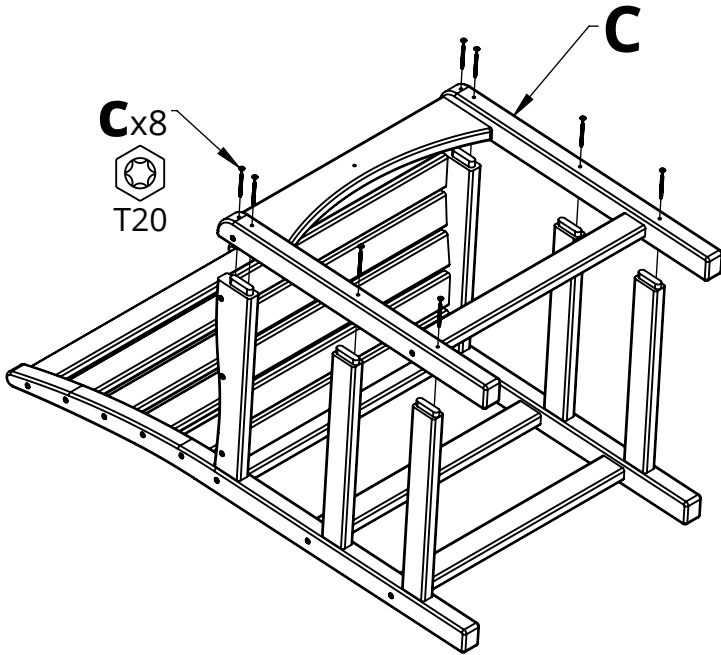
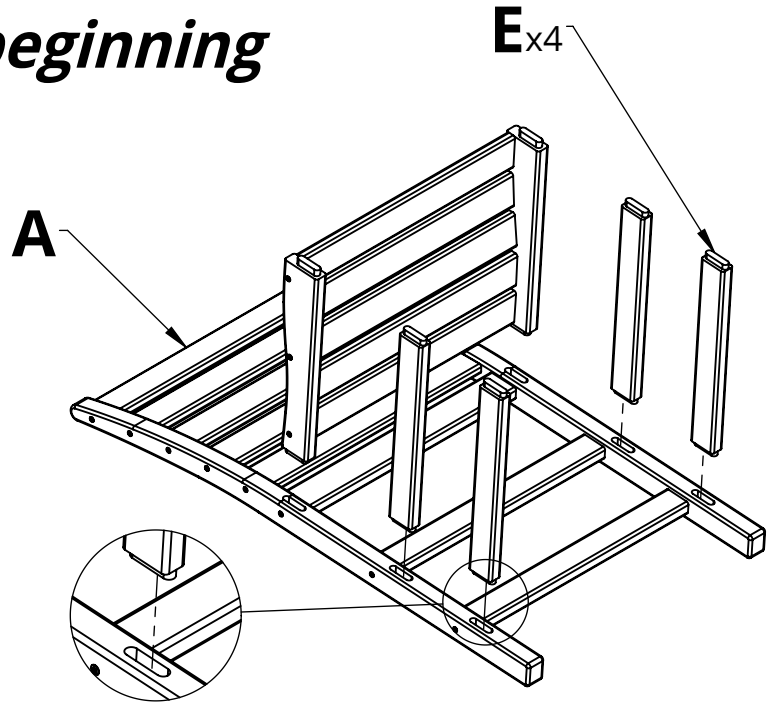

2. Attach Part C using the hardware shown

3. Turn the assembly over & attach it as shown

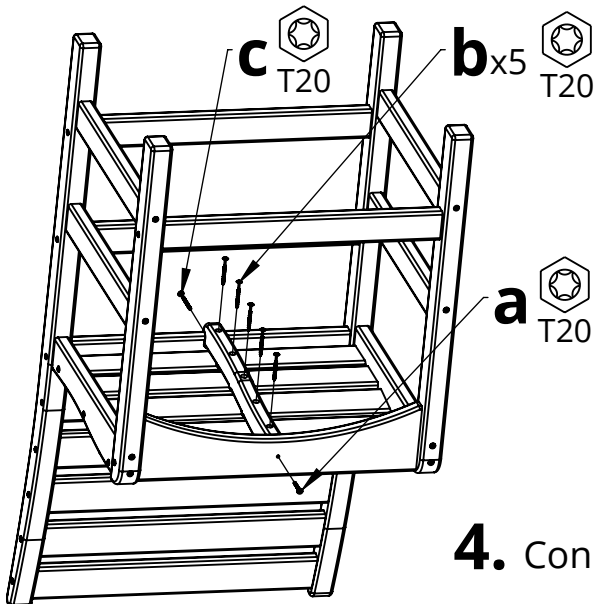
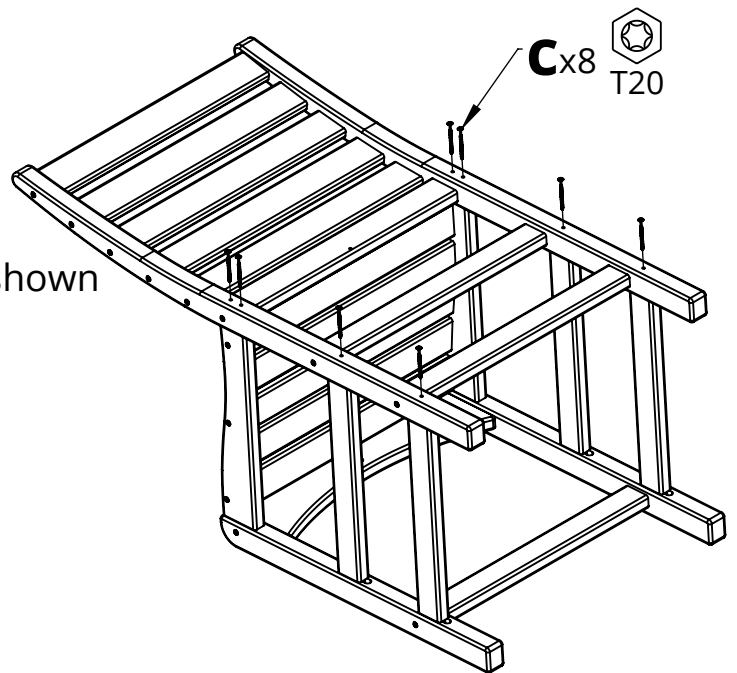

4. Connect Part D to the underside of Part B as shown