

PARTS

PART	DESCRIPTION	PART NO.	QTY
A	BASE SIDE ASSEMBLY	SA-00061	2
B	SWIVEL SUPPORT	PRT-00411	2
C	BASE SPREADER	PRT-00410	2
D	FOOTREST	PRT-00428	1
E	BOTTOM BASE SPREADER	PRT-00425	2
F	SEAT ASSEMBLY	SA-00229	1
G	LEFT ARM	PRT-00417	1
H	RIGHT ARM	PRT-00418	1
I	LEFT FRONT LEG	PRT-00415	1
J	RIGHT FRONT LEG	PRT-00416	1
K	FRONT RAIL	PRT-00414	1
L	BACK ASSEMBLY	SA-00227	1

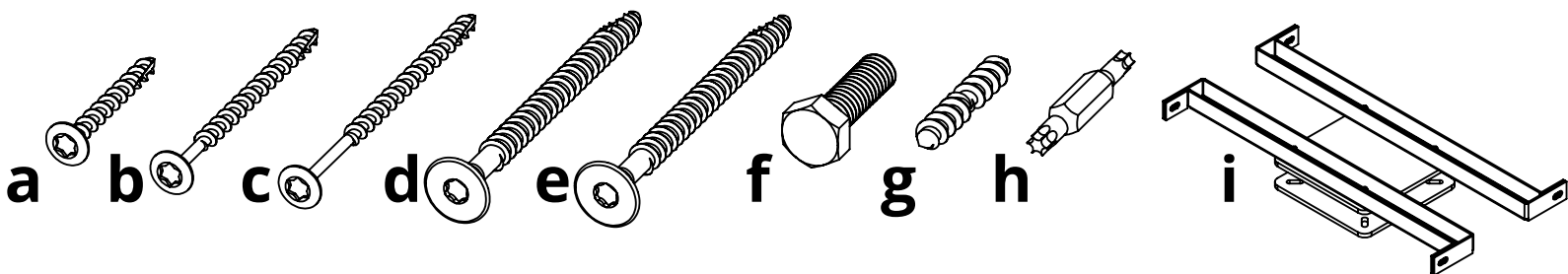

HARDWARE

PART	DESCRIPTION	PART NO.	QTY
a	#8 X 1-1/2" TORX SCREW	H-0000-S815	2
b	#8 X 2-1/2" TORX SCREW	H-0000-S825	13
c	#8 X 3" TORX SCREW	H-0000-S83	16
d	1/4"-10 X 3" LAG SCREW PAINTED	H-0000-S103	4
e	1/4"-10 X 3" LAG SCREW UNPAINTED	H-0000-S103	4
f	1" HEX BOLT 5/16" DIA	H-0000-HB1	4
g	DOUBLE SCREW	H-0000-DS	2
h	T20 & T25 TORX BIT	H-0000-CTD	1
i	PIEDMONT SWIVEL ASSEMBLY-GEN 3	H-0000-SA3	1

Suggested Tools: Drill, Plastic Mallet, 1/2" Socket Wrench

Please read entire instructions before beginning

- 1.** Attach Parts C & E to A using Hardware c & repeat for the 2nd side

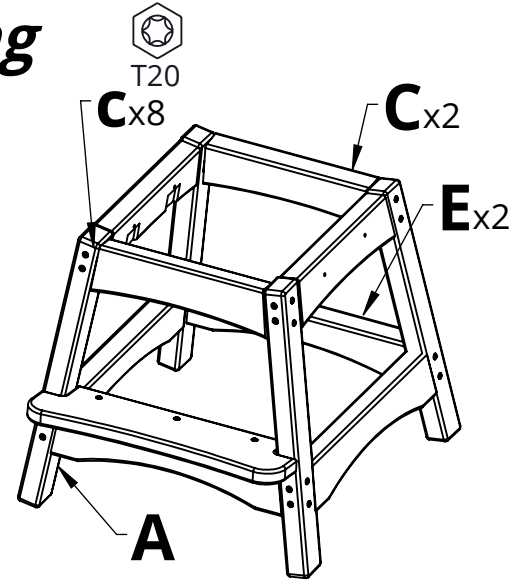

- 2.** Attach Part D with Hardware b

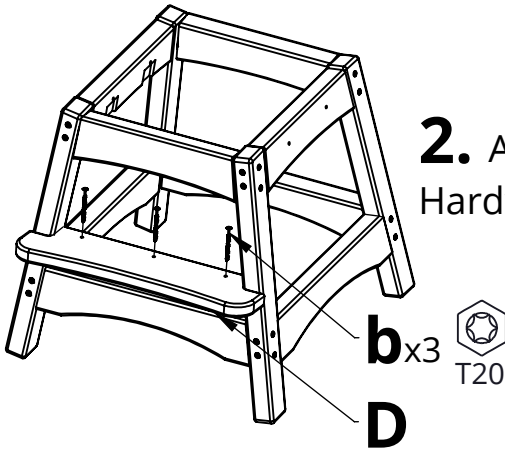

- 3.** While upside down press, or hammer, Parts B into the grooves & attach them using Hardware d

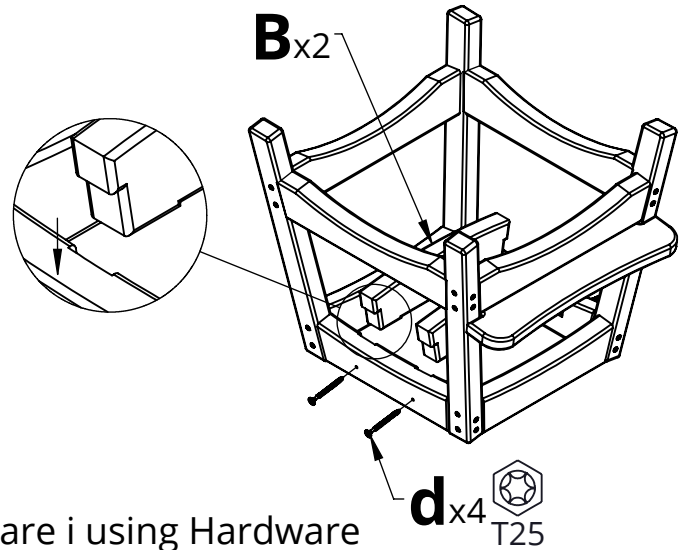

- 4.** Connect Hardware i using Hardware e as shown. Rotate the top plate/brackets to expose the holes in the bottom plate when installing the screws.

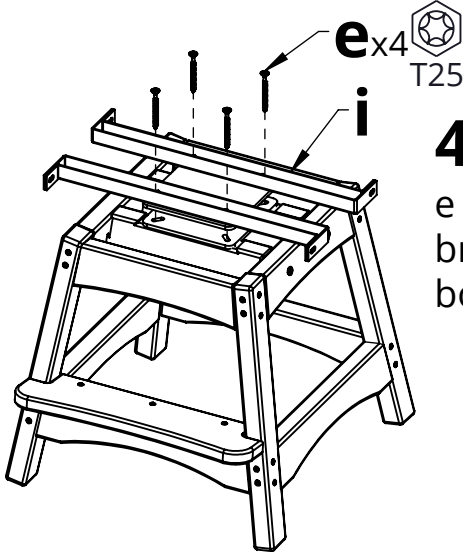

- 5.** Attach the seat base (Part F) to the swivel brackets using (4) of hardware f.

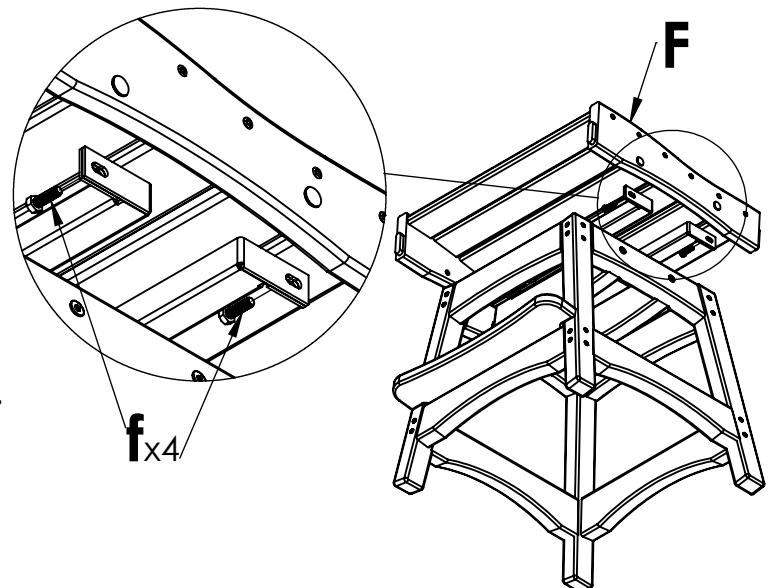

- 6.** Connect Part H to J with Hardware g by rotating Part H clockwise until the assembly is tight
- 7.** Repeat Step 6 for Parts G & I

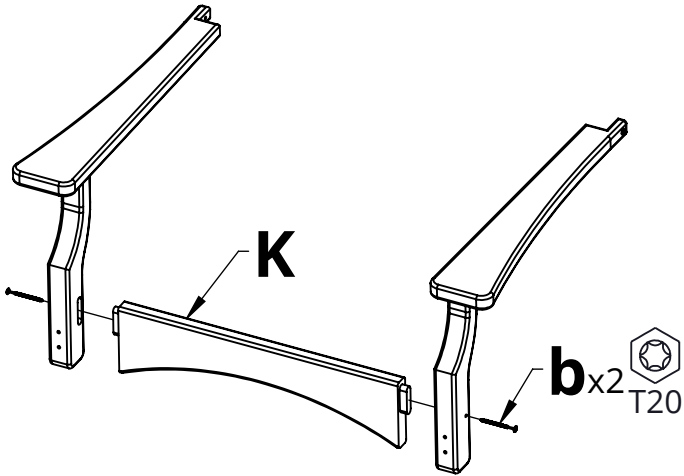
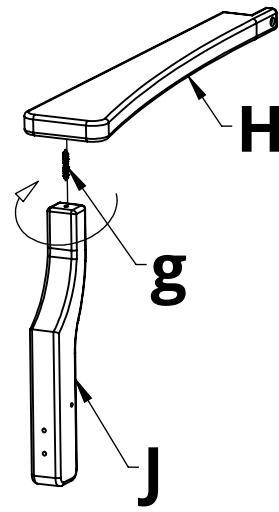

- 8.** Connect the previous assemblies to Part K using Hardware b

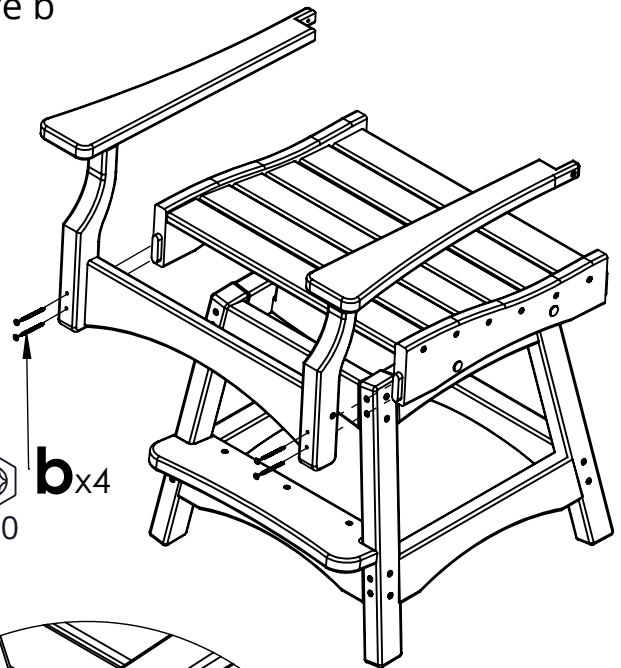

- 9.** Connect the assembly from Step 8 to Part F using the hardware shown

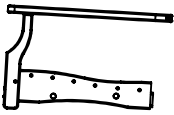

Side View

Note: Make sure Step 8 is connected on the front of Part F as shown

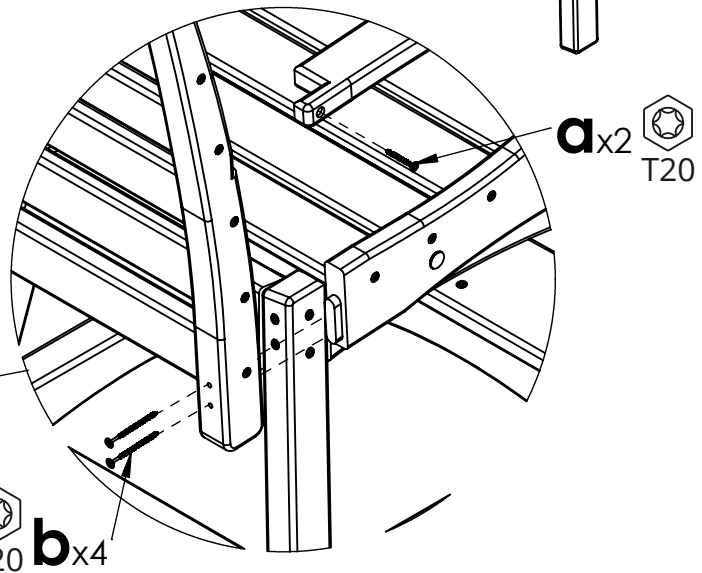
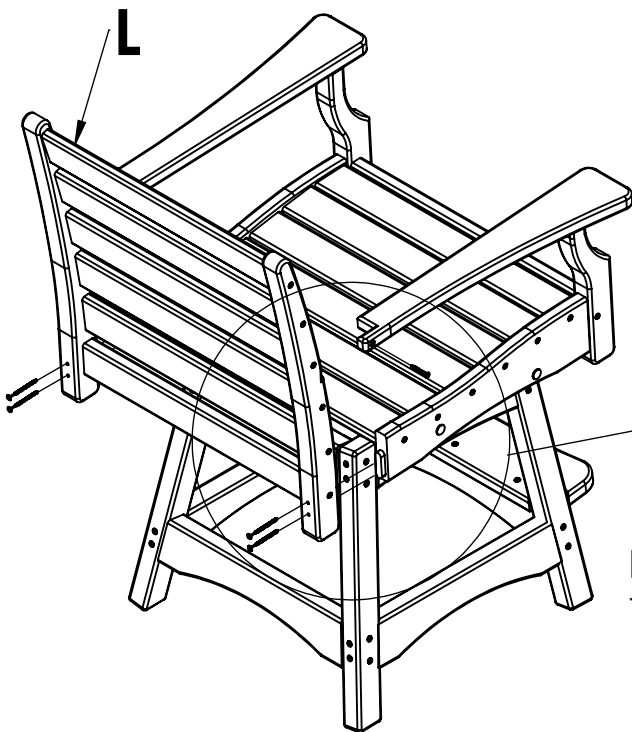

- 10.** Attach Part L using the hardware shown