

breezesta™

**PIEDMONT BAR SWIVEL CHAIR**  
**PT-0603**

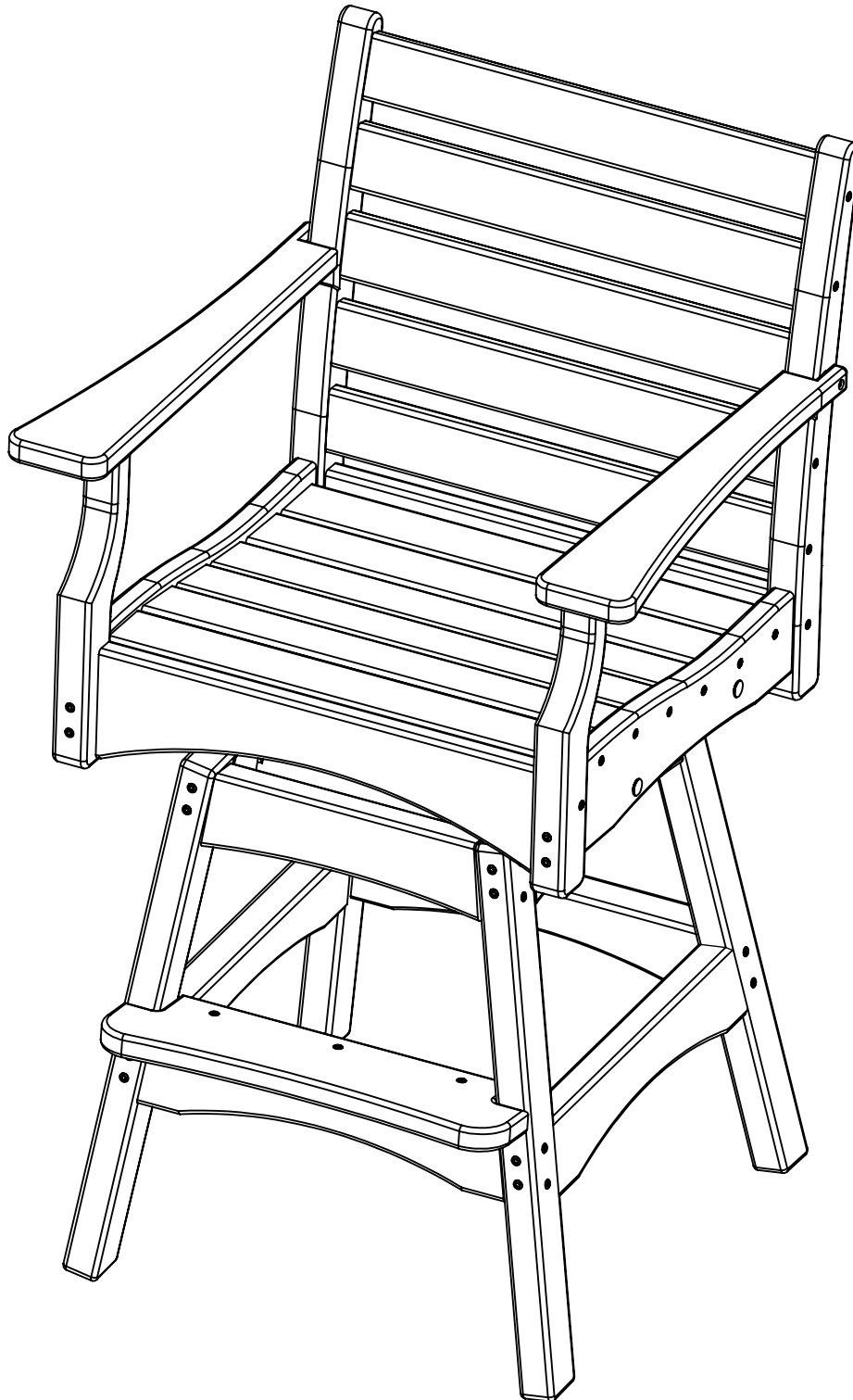

REV06-2/2020

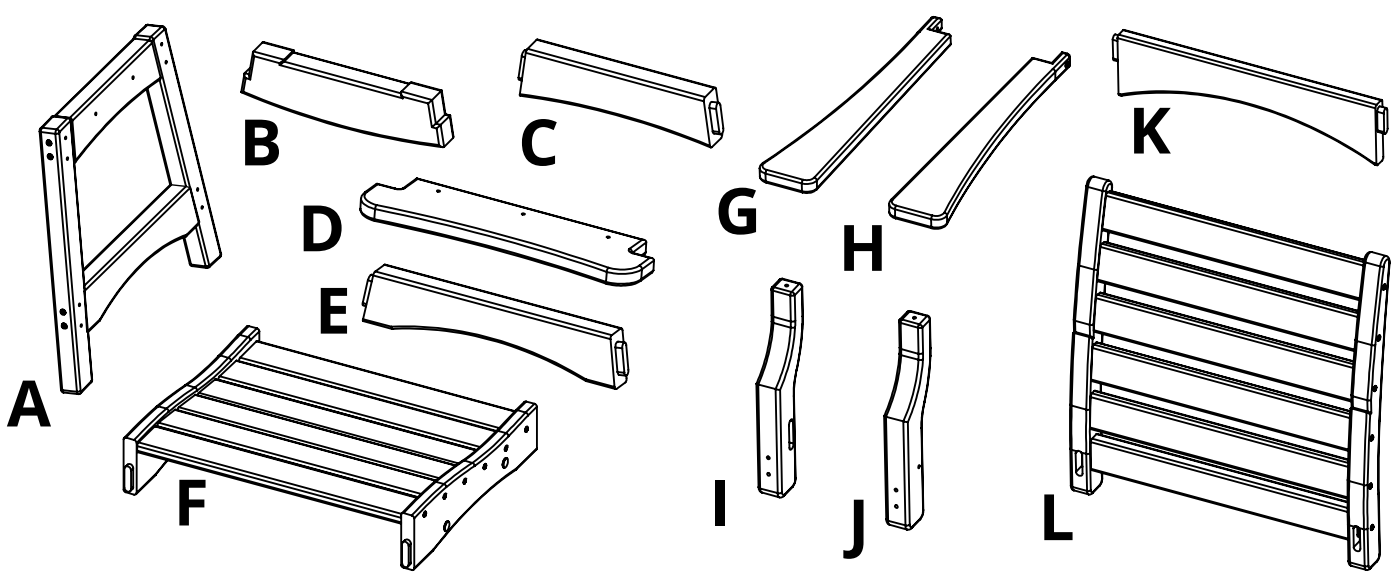

## PARTS

PART	DESCRIPTION	PART NO.	QTY
A	BASE SIDE ASSEMBLY	SA-00231	2
B	SWIVEL SUPPORT	PRT-00411	2
C	BASE SPREADER	PRT-00410	2
D	FOOTREST	PRT-00428	1
E	BOTTOM BASE SPREADER	PRT-00425	2
F	SEAT ASSEMBLY	SA-00229	1
G	LEFT ARM	PRT-00417	1
H	RIGHT ARM	PRT-00418	1
I	LEFT FRONT LEG	PRT-00415	1
J	RIGHT FRONT LEG	PRT-00416	1
K	FRONT RAIL	PRT-00414	1
L	BACK ASSEMBLY	SA-00227	1

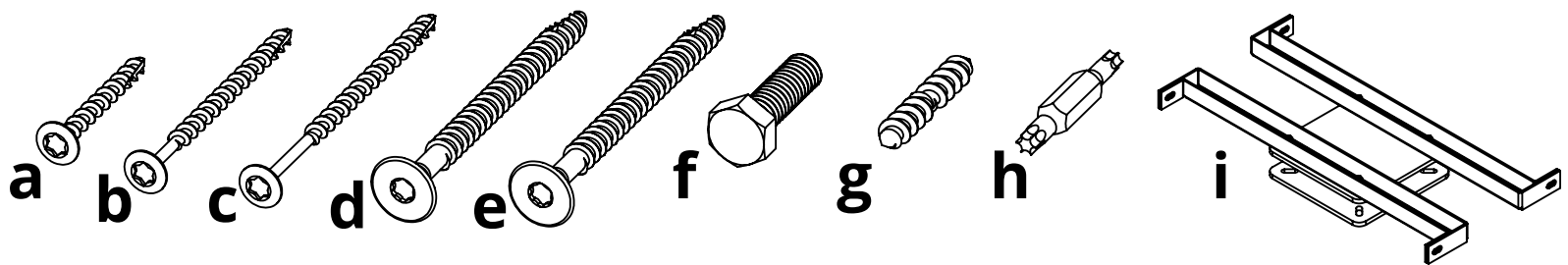

## HARDWARE

PART	DESCRIPTION	PART NO.	QTY
a	#8 X 1-1/2" TORX SCREW	H-0000-S815	2
b	#8 X 2-1/2" TORX SCREW	H-0000-S825	13
c	#8 X 3" TORX SCREW	H-0000-S83	16
d	1/4"-10 X 3" LAG SCREW PAINTED	H-0000-S103	4
e	1/4"-10 X 3" LAG SCREW UNPAINTED	H-0000-S103	4
f	1" HEX BOLT 5/16" DIA	H-0000-HB1	4
g	DOUBLE SCREW	H-0000-DS	2
h	T20 & T25 TORX BIT	H-0000-CTD	1
i	PIEDMONT SWIVEL ASSEMBLY-GEN 3	H-0000-SA3	1

**Suggested Tools:** Drill, Plastic Mallet, 1/2" Socket Wrench

# Please read entire instructions before beginning

**1.** Attach Parts C & E to A using Hardware c & repeat for the 2nd side

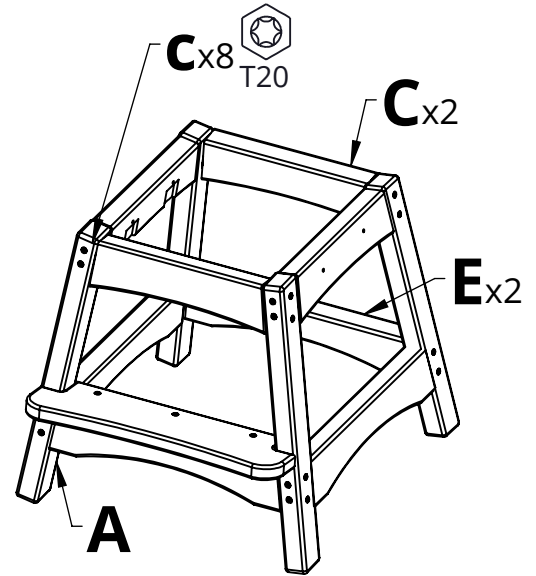

**2.** Attach Part D with Hardware b

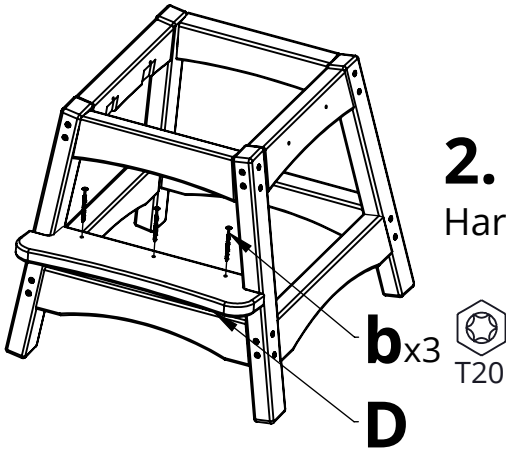

**3.** While upside down press, or hammer, Parts B into the grooves & attach them using Hardware d

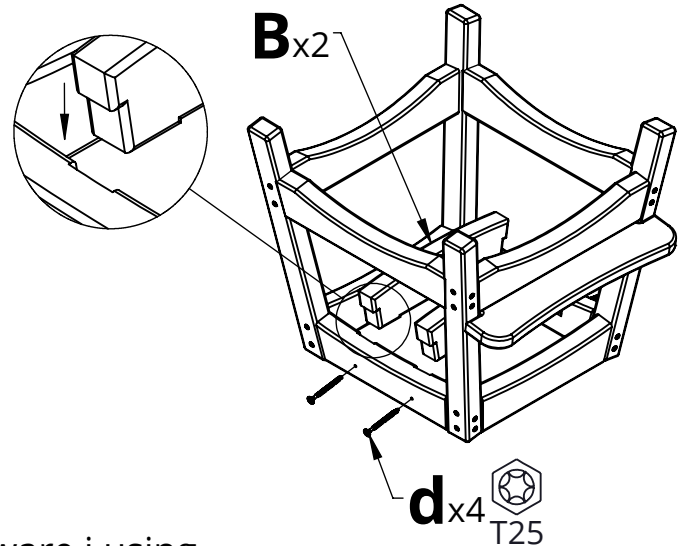

**4.** Connect Hardware i using Hardware e as shown

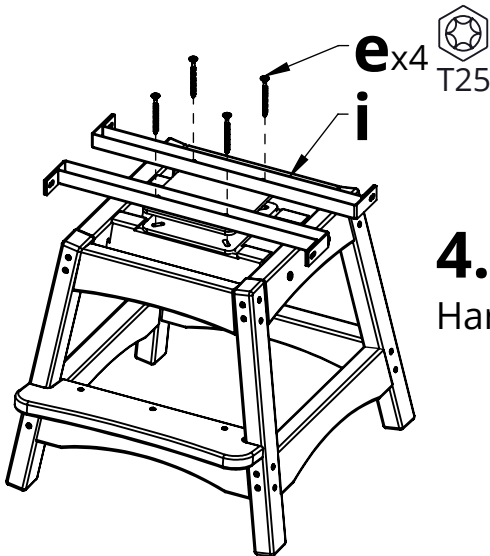

**5.** Attach Seat Assembly (Part F) to the swivel brackets using the hardware shown.

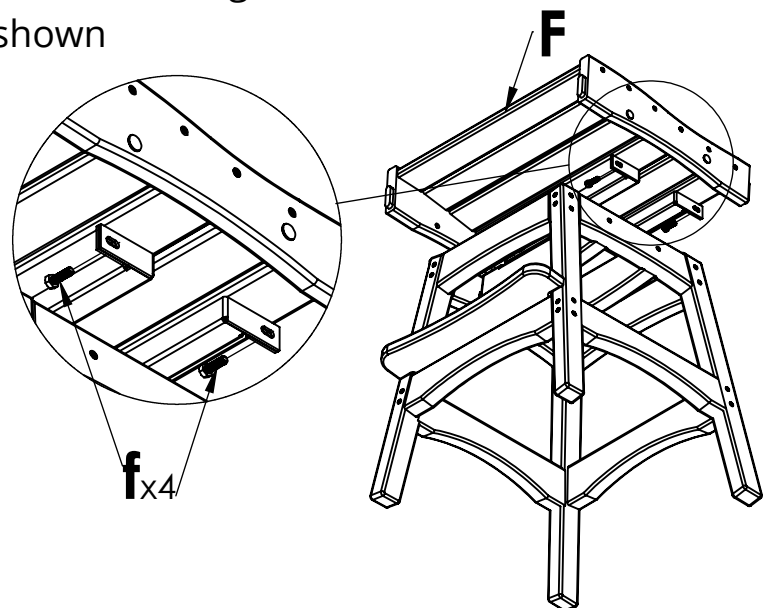

**6.** Connect Part H to J with Hardware g by rotating Part H clockwise until the assembly is tight

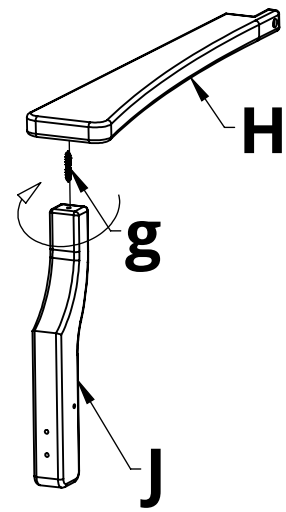

**7.** Repeat Step 5 for Parts G & I

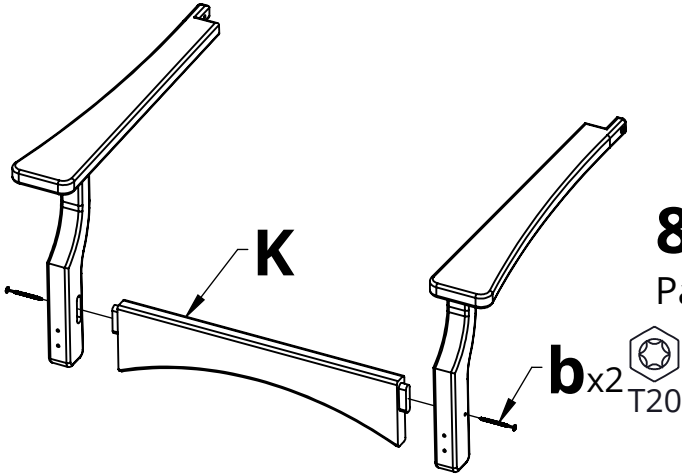

**8.** Connect the previous assemblies to Part K using Hardware b

**9.** Connect the assembly from Step 8 to Part F using the hardware shown

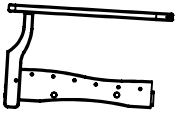

**Side View**

**Note:** Make sure Step 9 is connected on the front of Part F as shown

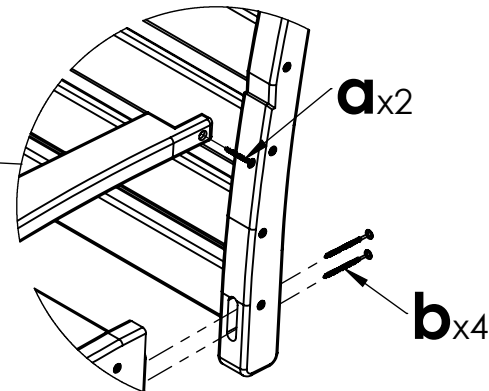
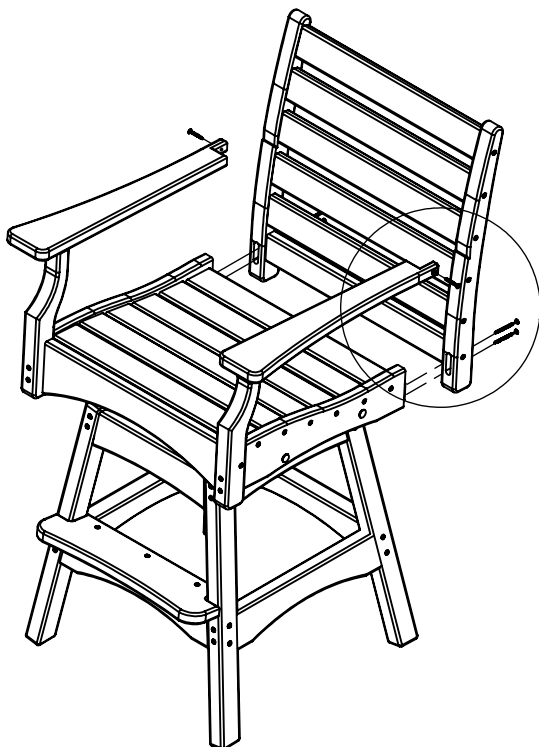
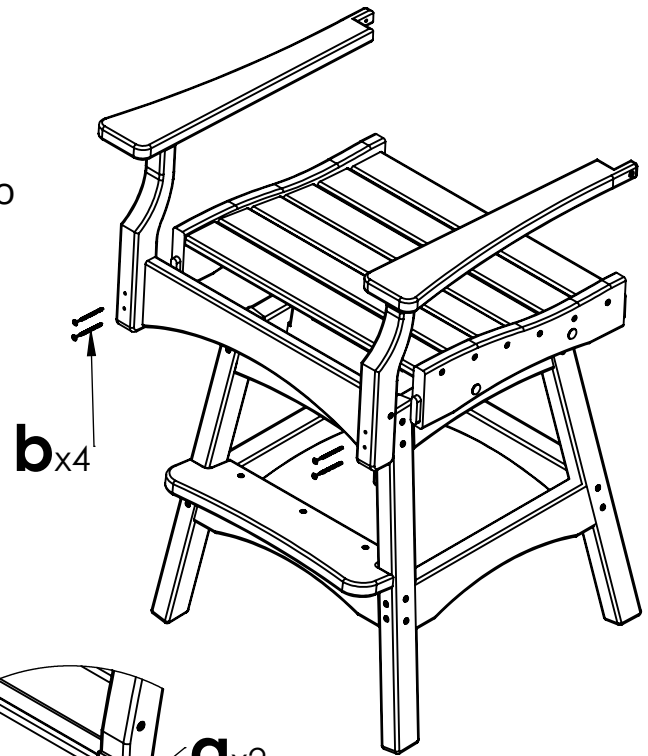

**10.** Attach Part L using the hardware shown