

A

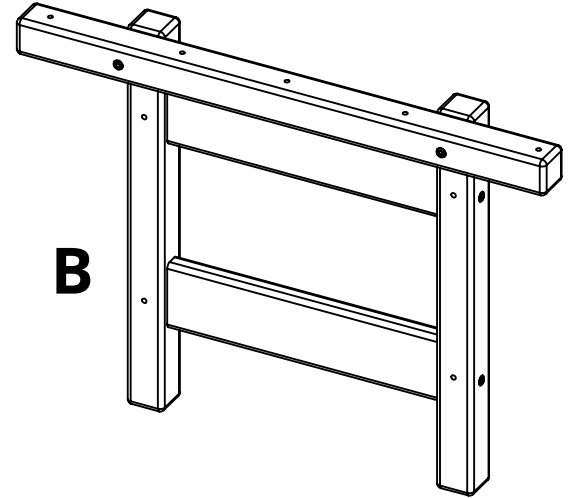

B



C

PARTS

PART	DESCRIPTION	PART NO.	QTY
A	TABLE TOP ASSEMBLY	SA-00259	1
B	SIDE ASSEMBLY	SA-00258	2
C	STOOL SPREADER	SS-11.25	4

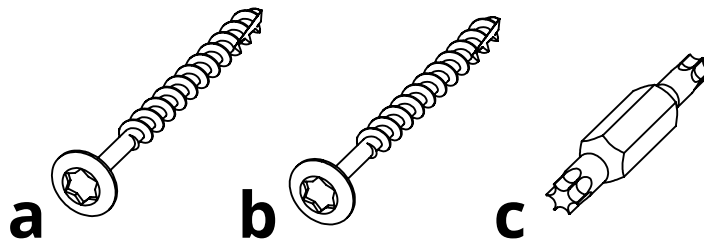

a

b

c

HARDWARE

PART	DESCRIPTION	PART NO.	QTY
a	#8 X 2" TORX SCREW (COLORED)	H-0000-S82	8
b	#8 X 2" TORX SCREW (UNCOLORED)	H-0000-S82	10
e	TORX BIT	H-0000-CTD	1

Suggested Tools: Drill, Plastic Mallet

Please read entire instructions before beginning

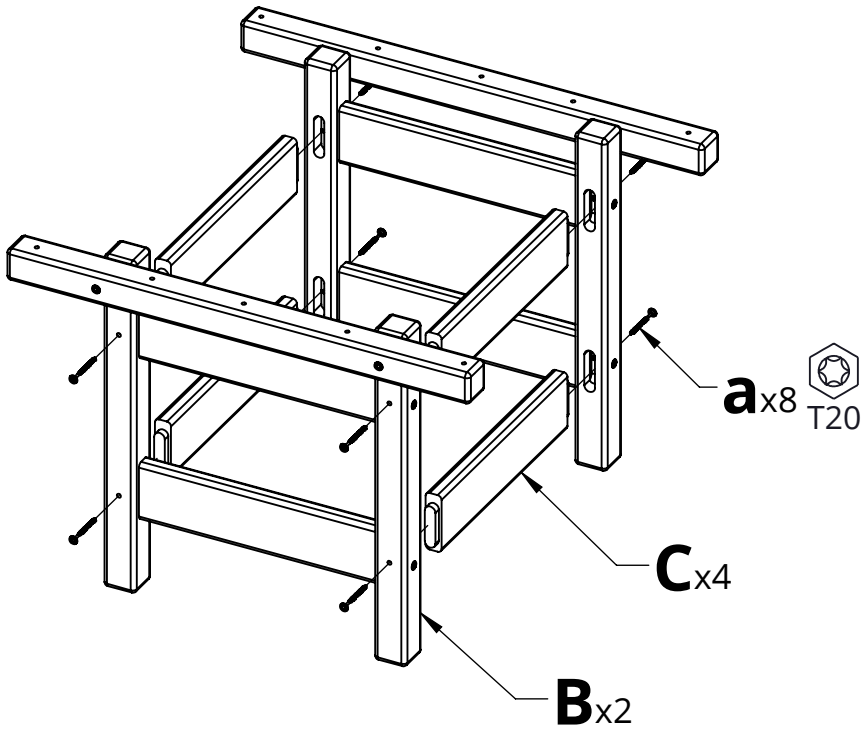

1. Attach Parts B to Parts C using Hardware a

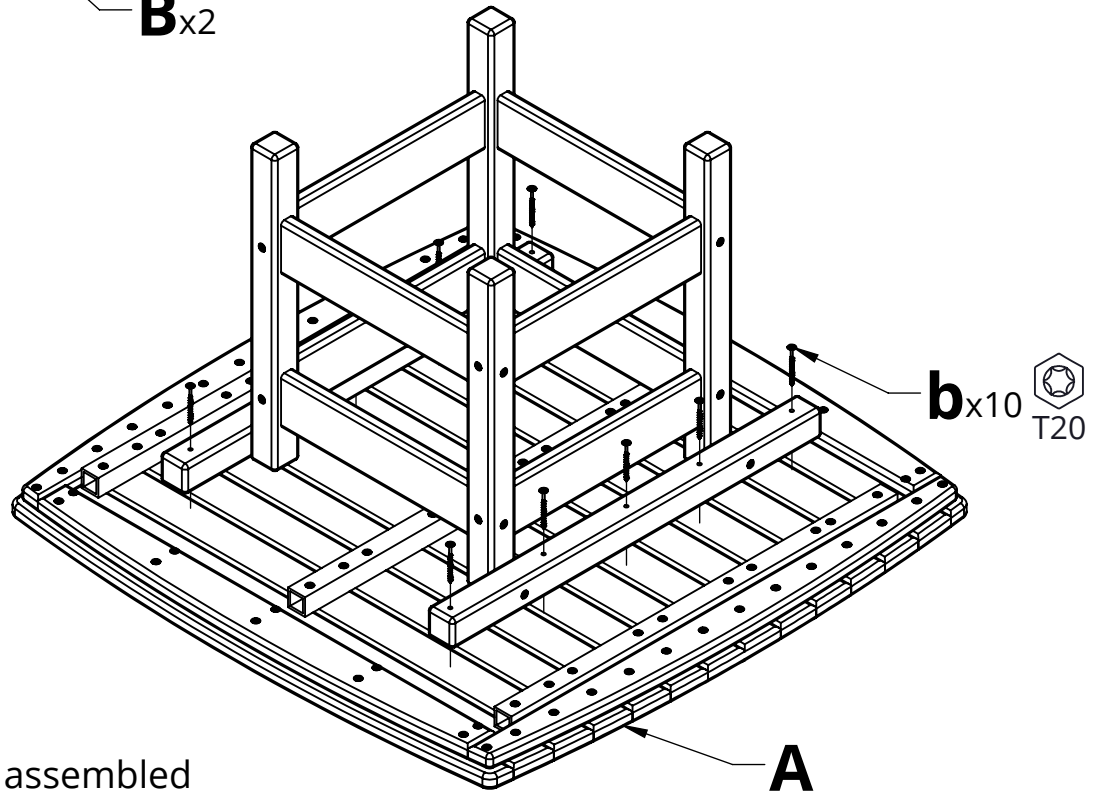

2. Attach Part A to assembled piece from Step 1 using Hardware b

May be easier if assembled upside down