

breezesta™

SKYLINE HIGH BACK ROCKER
SK-0400

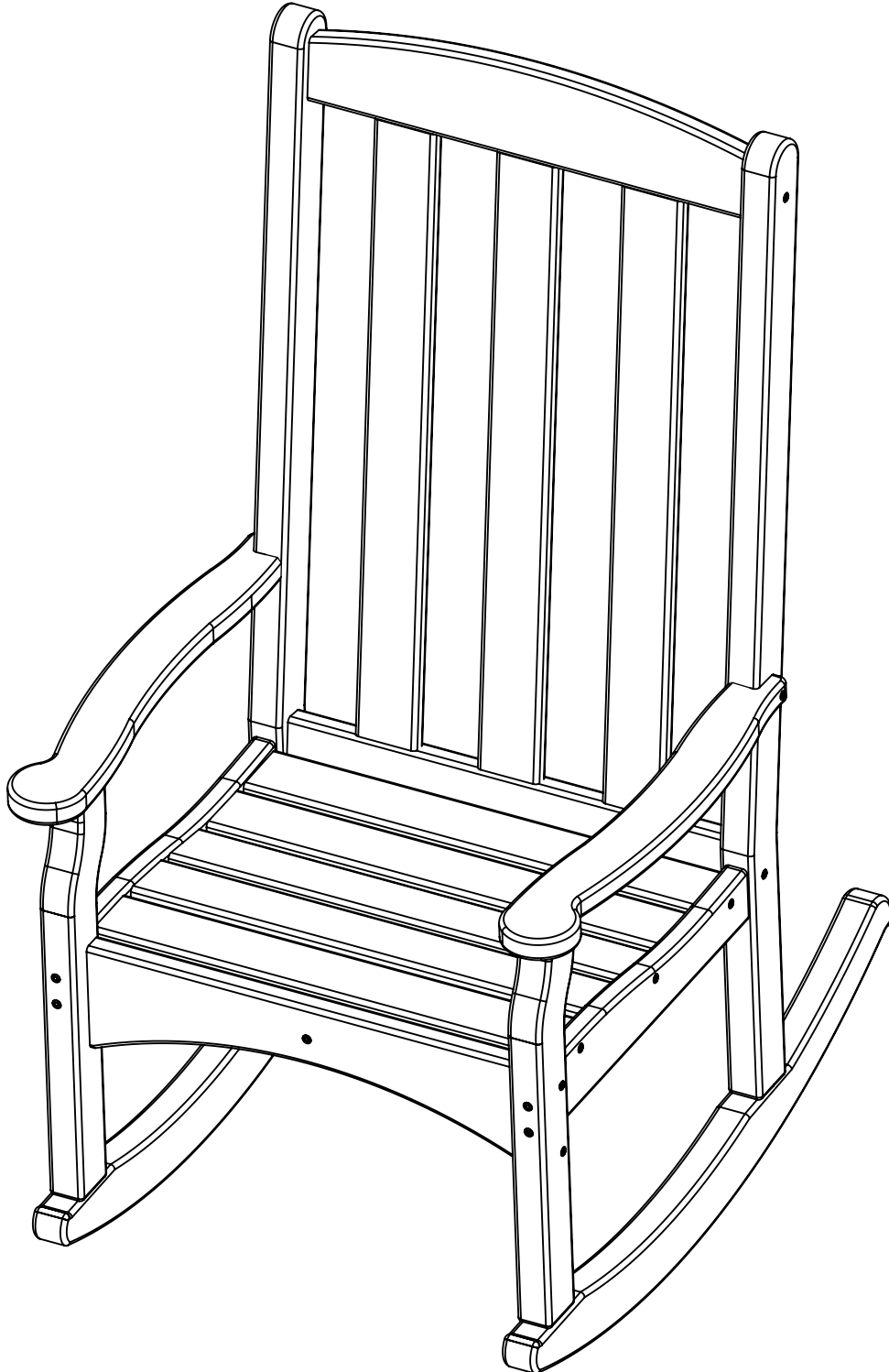

REV00-1/19

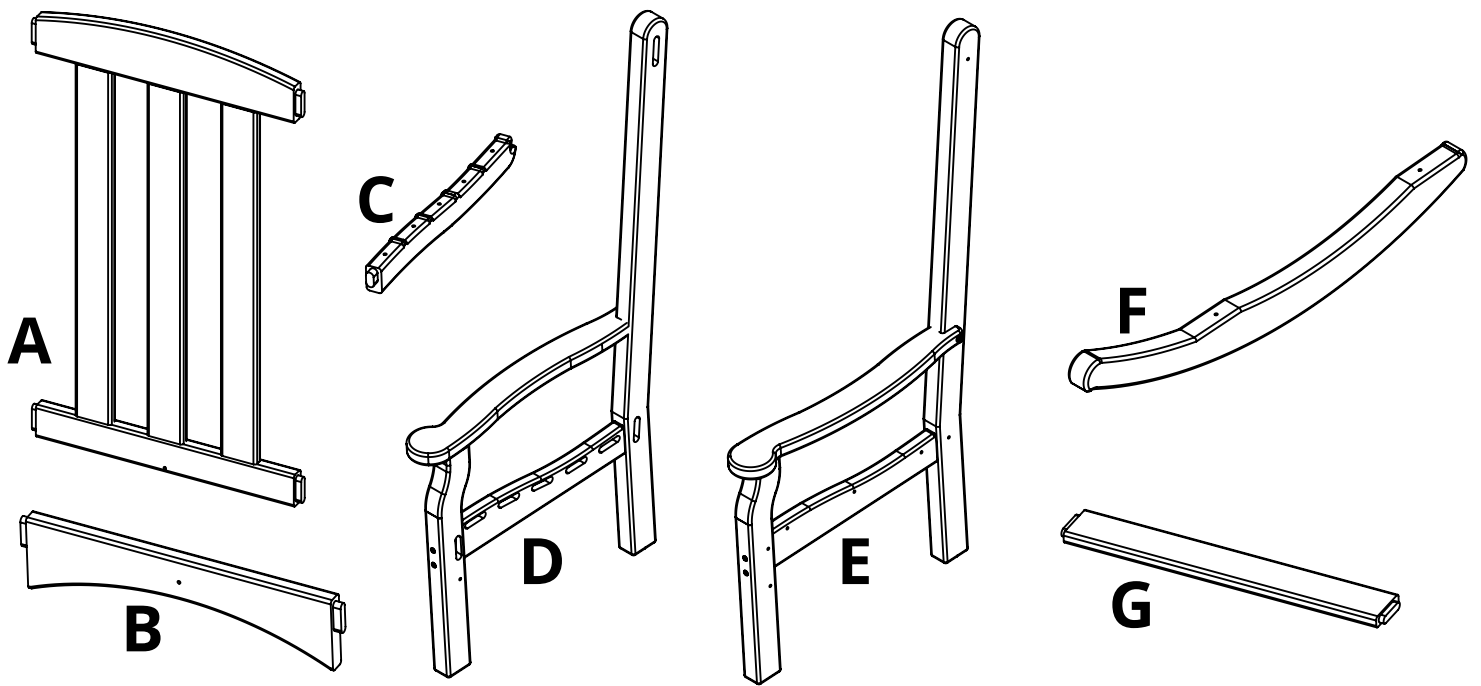

PARTS

PART	DESCRIPTION	PART NO.	QTY
A	BACK ASSEMBLY	SA-00168	1
B	FRONT RAIL	PRT-00293	1
C	SEAT SUPPORT	PRT-00294	1
D	LEFT SIDE ASSEMBLY	SA-00166	1
E	RIGHT SIDE ASSEMBLY	SA-00167	1
F	ROCKER	PRT-00161	2
G	STANDARD SEAT SLAT 21.25	SS-20.25	5

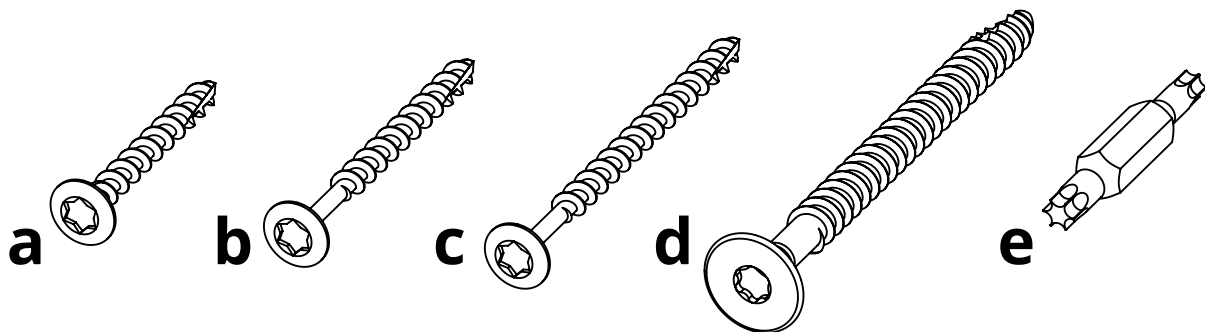

HARDWARE

PART	DESCRIPTION	PART NO.	QTY
a	#8 X 1-1/2" TORX SCREW	H-0000-S815	7
b	#8 X 2" TORX SCREW	H-0000-S82	5
c	#8 X 2-1/2" TORX SCREW	H-0000-S825	9
d	1/4"-10 X 3" LAG SCREW	H-0000-S103	4
e	T20 & T25 TORX BIT	H-0000-CTD	1

Suggested Tools: Drill, Plastic Mallet

Please read entire instructions before beginning

1. Attach Parts A, G, & B to Part D using Hardware a to connect Parts G and Hardware c elsewhere

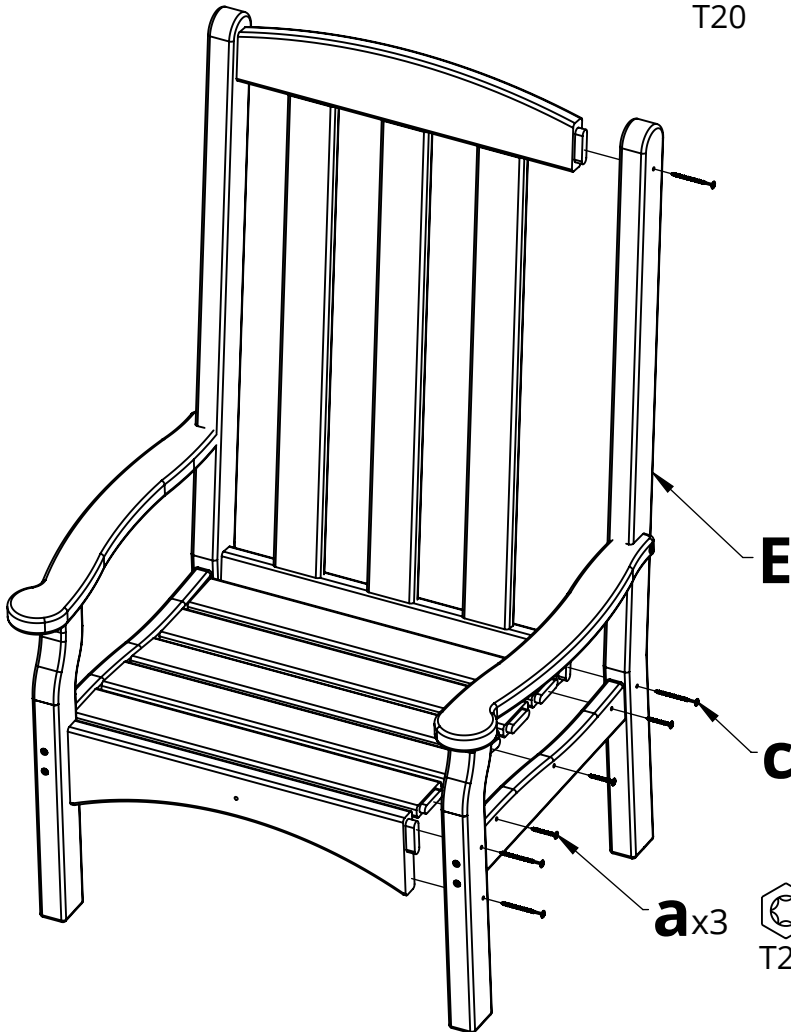
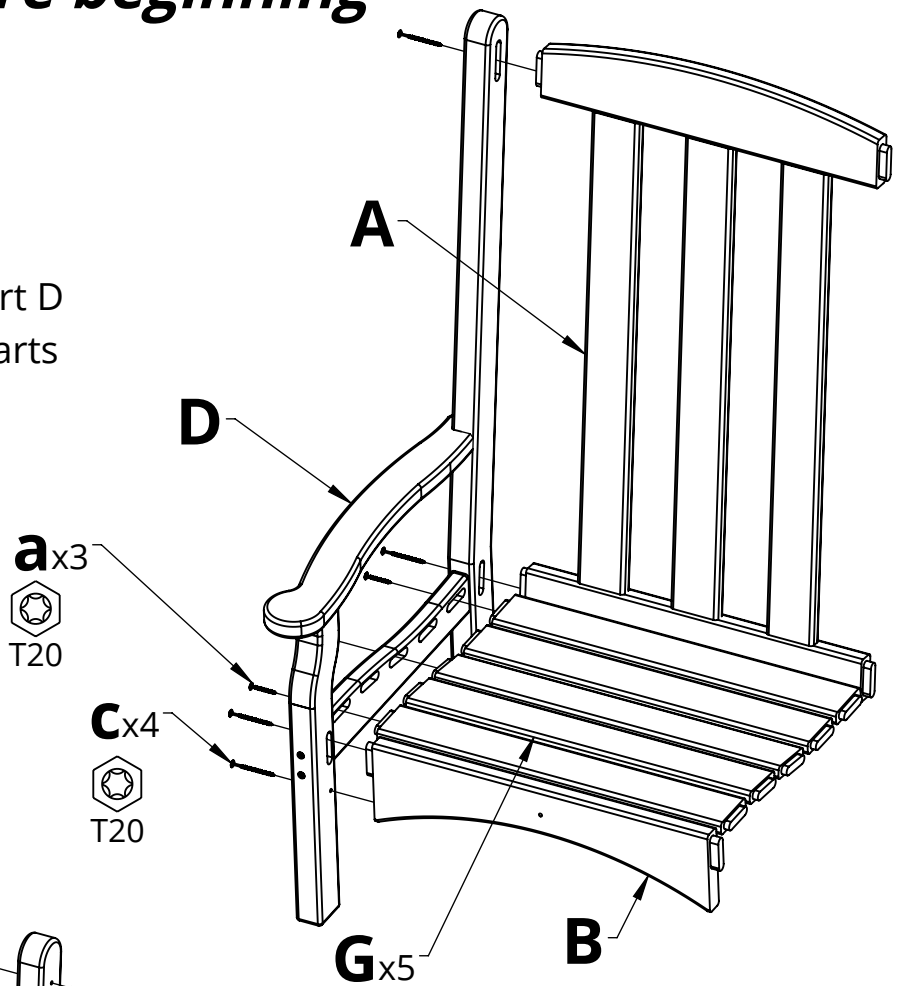

2. Attach Part E using the same hardware as Step 1

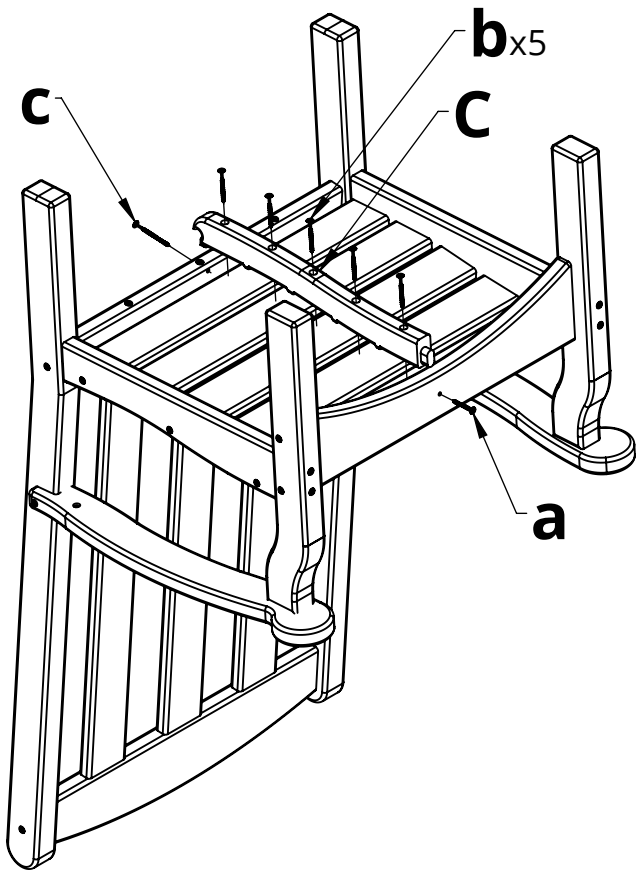

3. Connect Part C using Hardware a, b & c

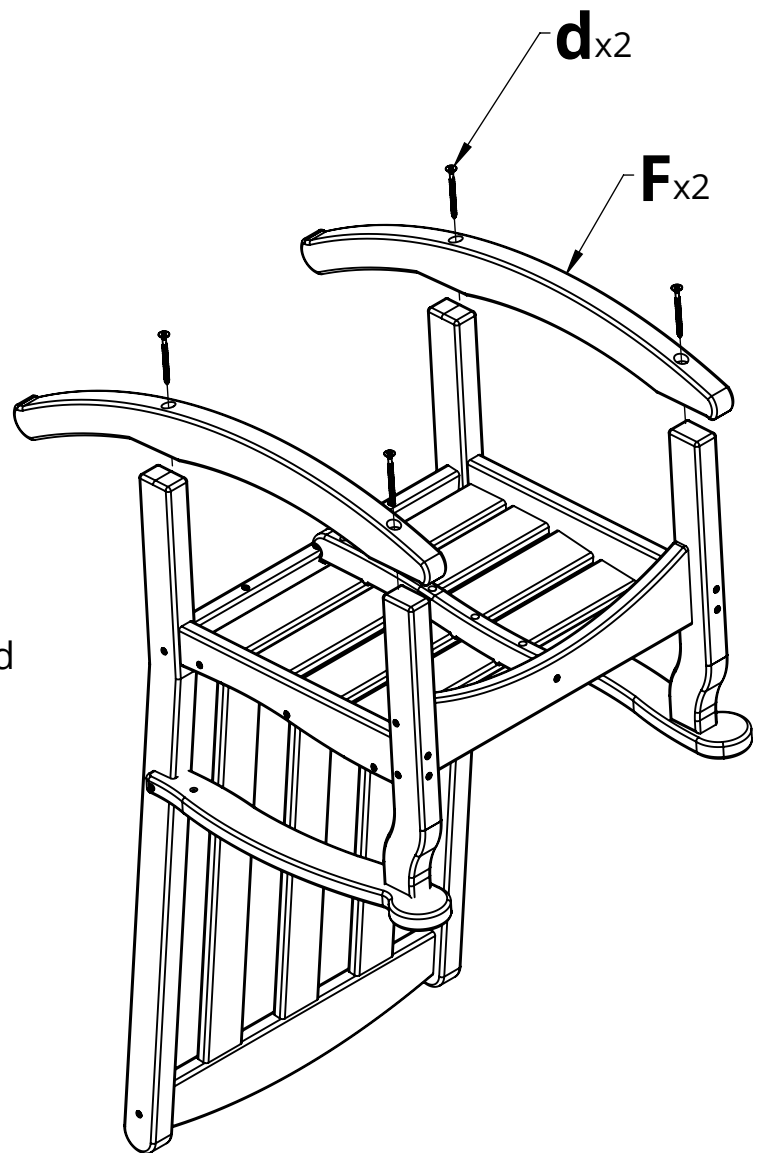

4. Place Parts F as shown to the previous assemblies using Hardware d

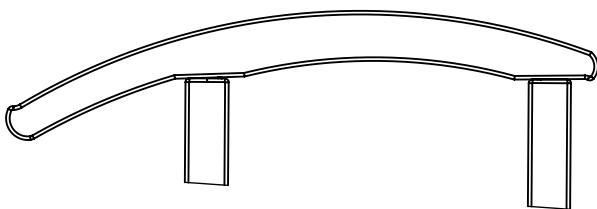

Part F placement