

breezesta™

SKYLINE DOUBLE HIGH BACK ROCKER
SK-0403

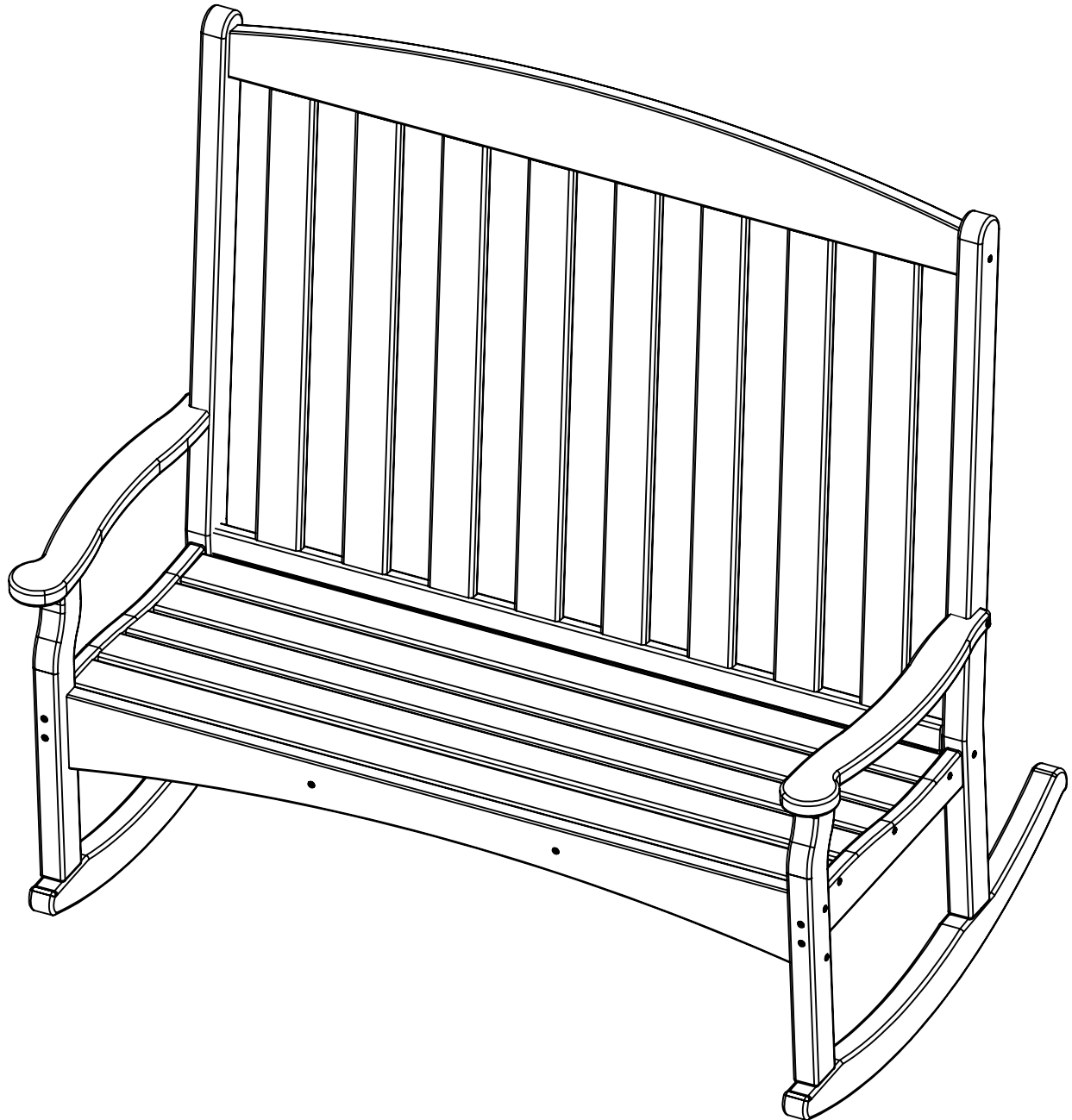

REV02-9/20

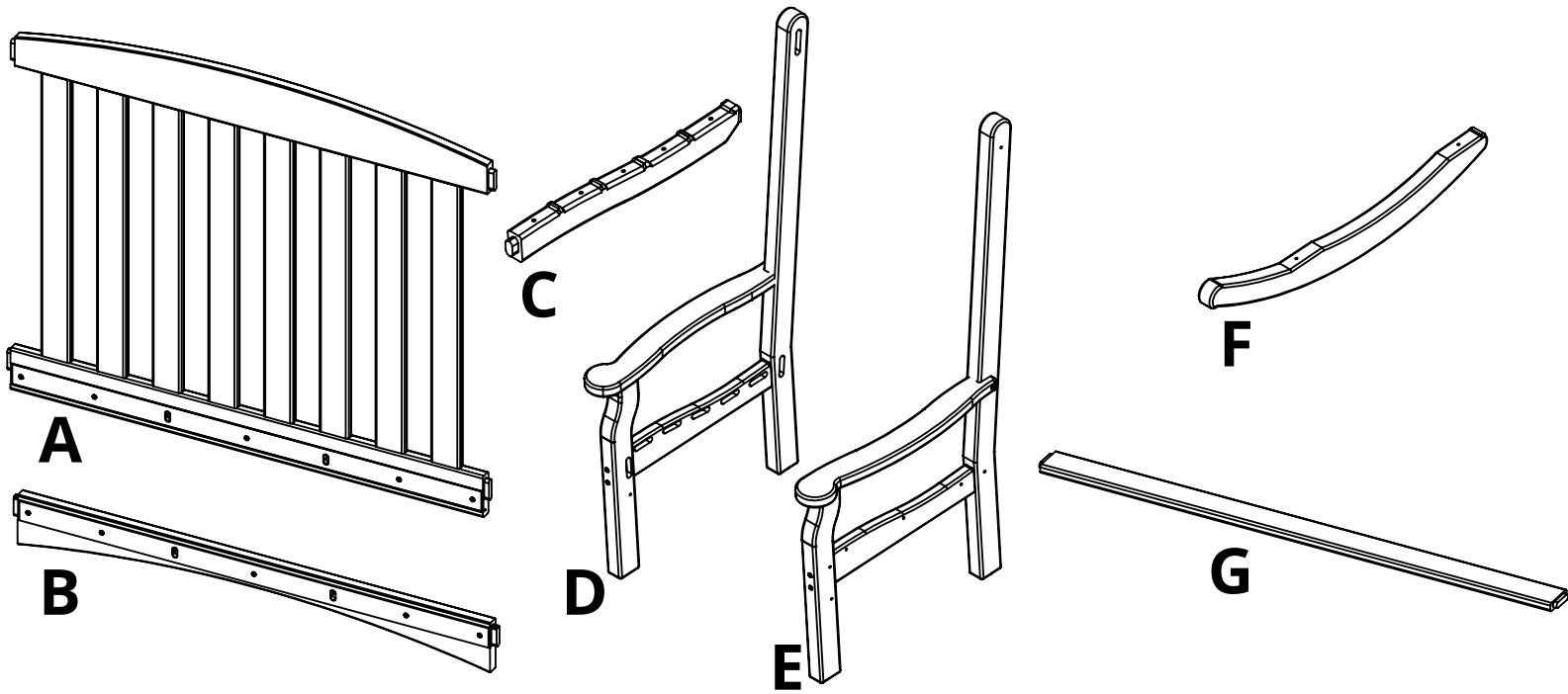

PARTS

PART	DESCRIPTION	PART NO.	QTY
A	BACK ASSEMBLY	SA-00441	1
B	FRONT RAIL ASSEMBLY 48"	SA-00197	1
C	SEAT SUPPORT	PRT-00865	2
D	LEFT SIDE ASSEMBLY	SA-00166	1
E	RIGHT SIDE ASSEMBLY	SA-00167	1
F	ROCKER	PRT-00161	2
G	48IN SEAT SLAT	SS-45.562	5

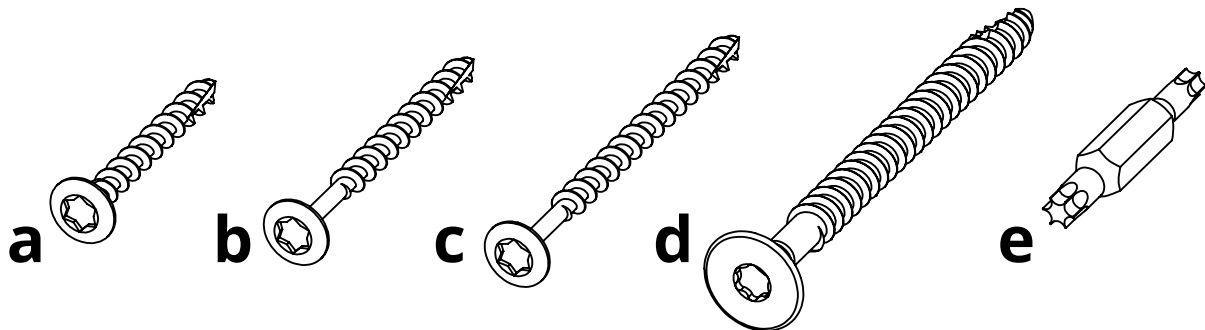

HARDWARE

PART	DESCRIPTION	PART NO.	QTY
a	#8 X 1-1/2" TORX SCREW	H-0000-S815	8
b	#8 X 2" TORX SCREW	H-0000-S82	10
c	#8 X 2-1/2" TORX SCREW	H-0000-S825	10
d	1/4"-10 X 3" LAG SCREW	H-0000-S103	4
e	T20 & T20 TORX BIT	H-0000-CTD	1

Suggested Tools: Drill, Plastic Mallet

Please read entire instructions before beginning

- 1.** Attach Parts A & B between Parts D & E using Hardware c

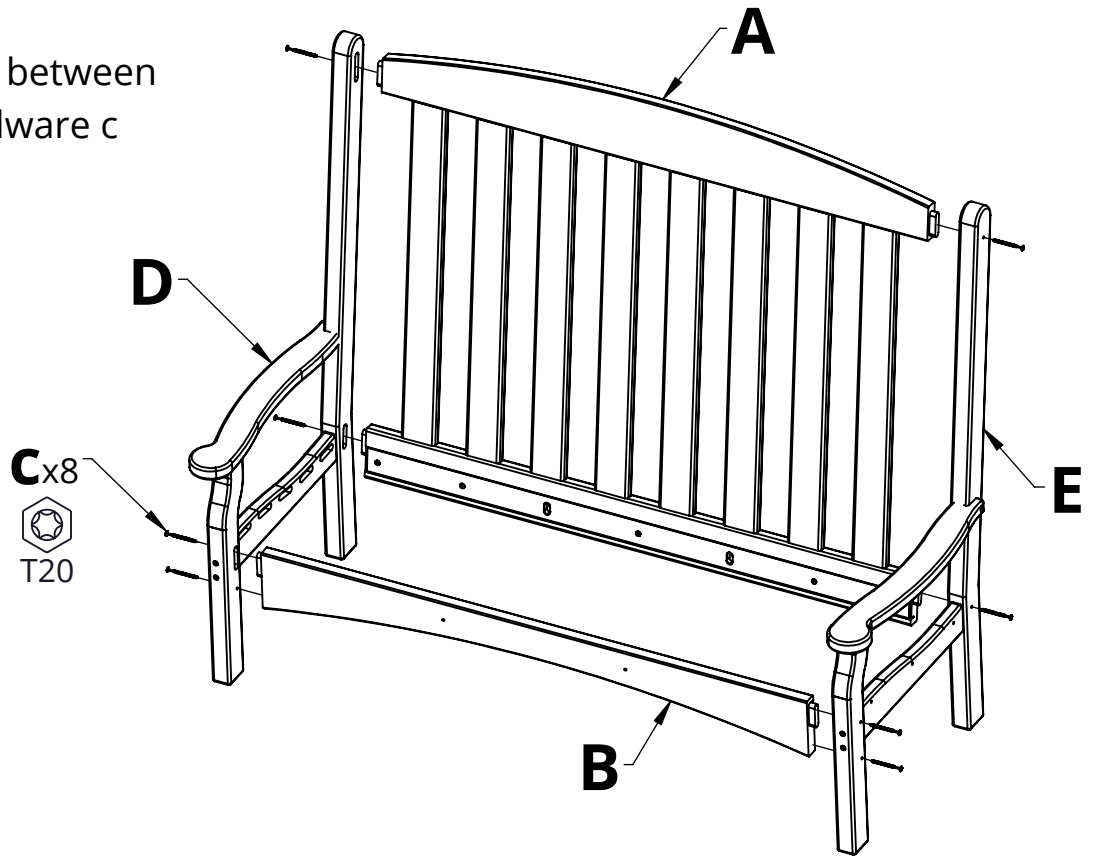

- 2.** Attach Parts C using the same hardware as Step 1

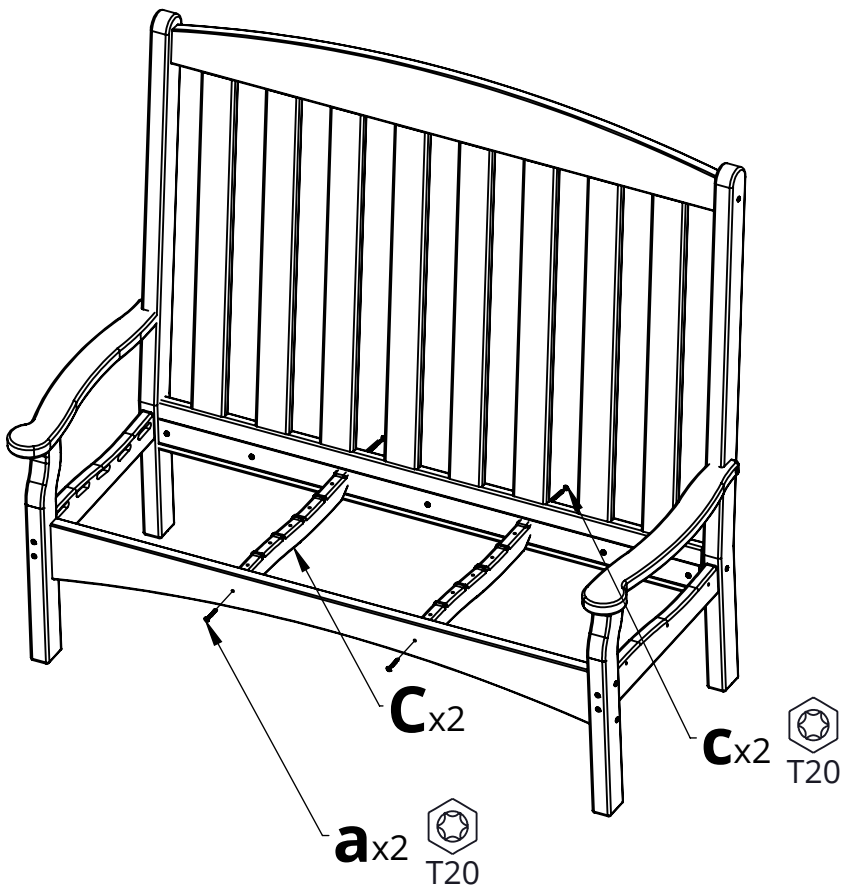

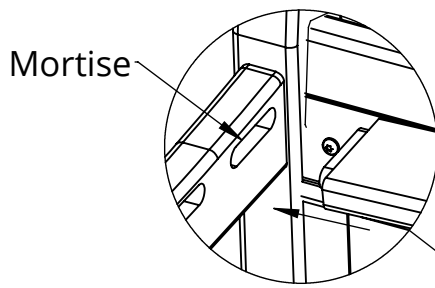

3. Place one end of the Parts G into the mortise & flex the other into the mortise on the other end

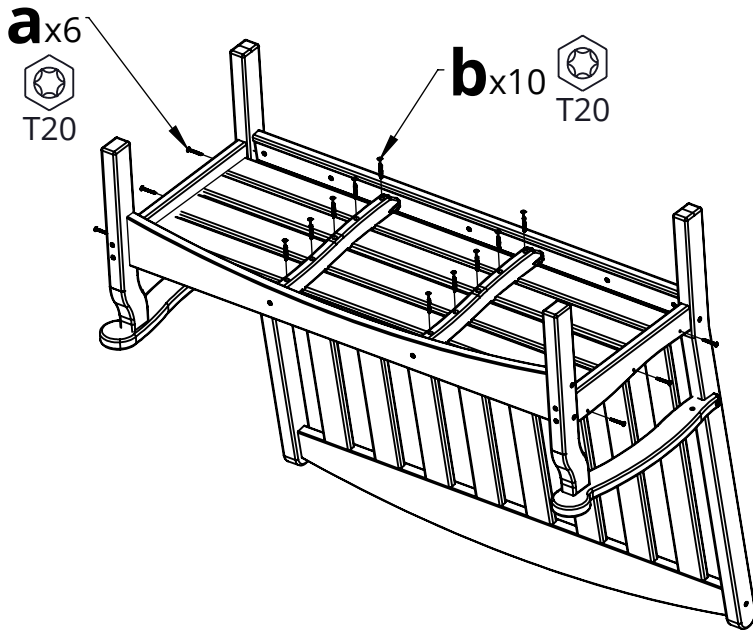
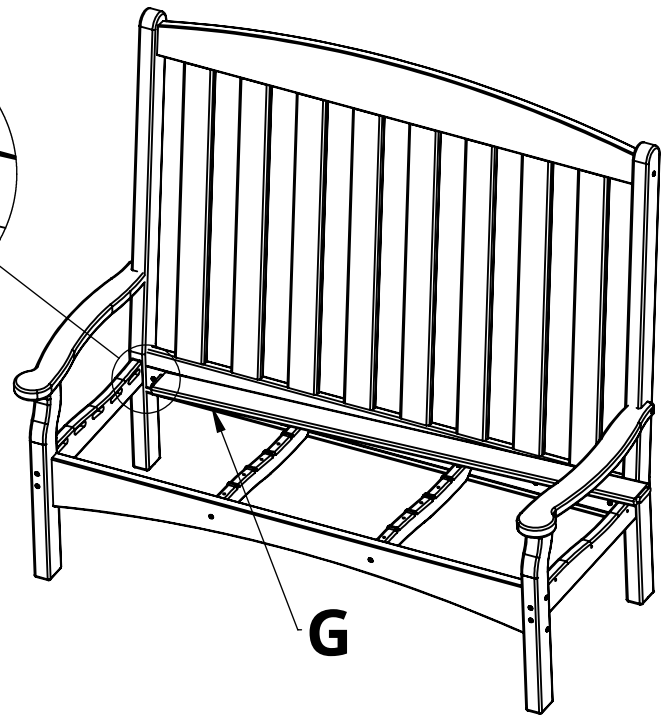

4. Secure Parts G with Hardware a & b

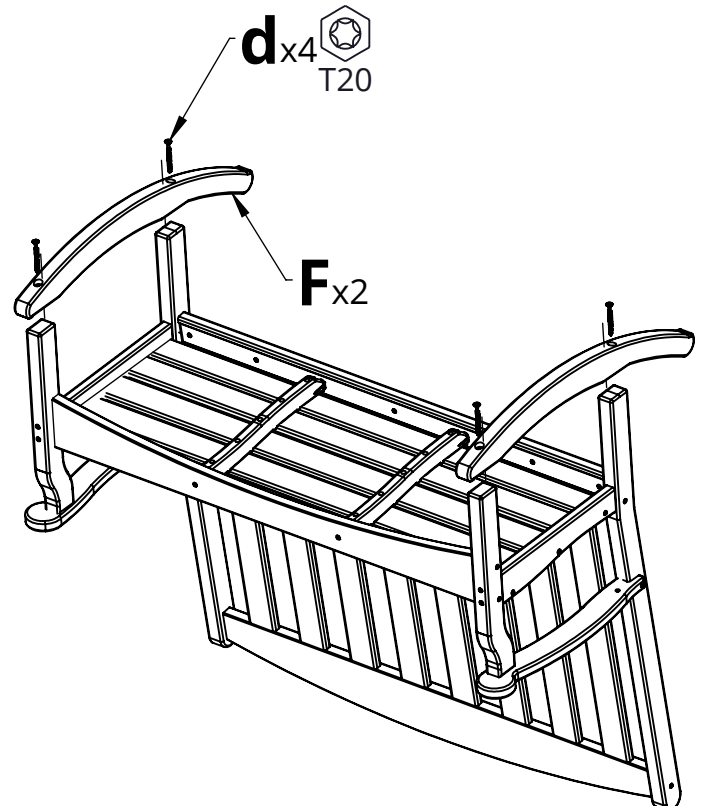

5. Attach Parts F to the previous assemblies using Hardware d