



# Service Manual

## 23" Insert

### Model Numbers:

DFI2309 MOD ~ to F

DFI2310 MOD ~ to F

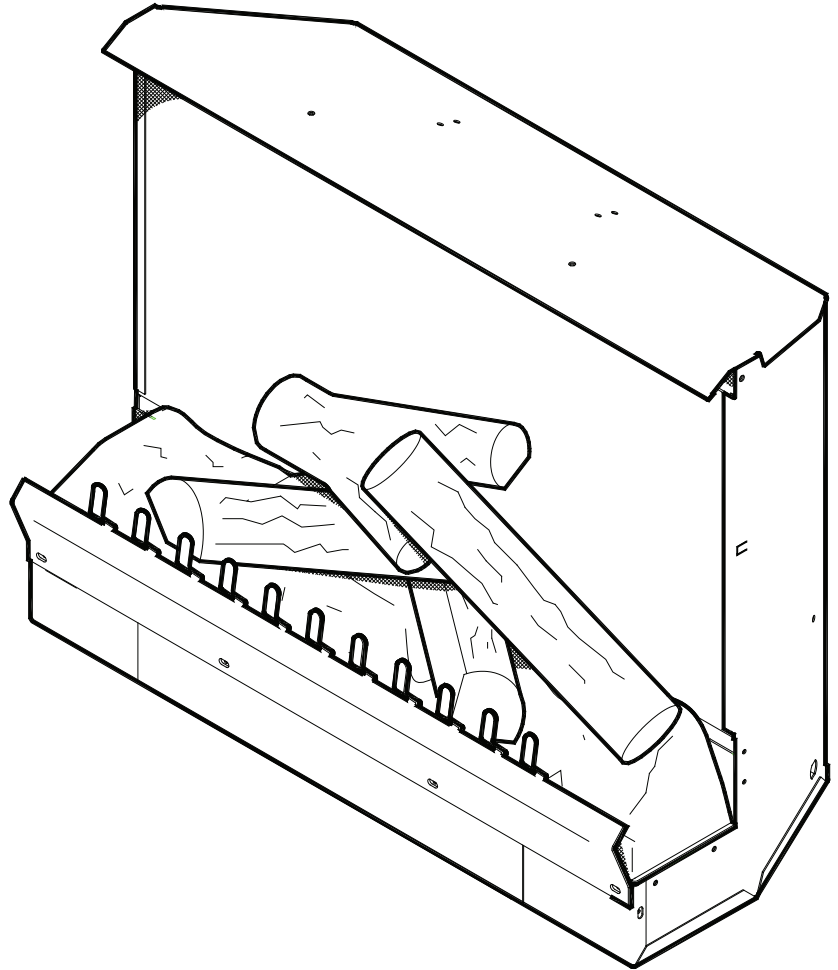

**IMPORTANT SAFETY INFORMATION:** Always read this manual first before attempting to service this fireplace. For your safety, always comply with all warnings and safety instructions contained in this manual to prevent personal injury or property damage.

Rev	PCN	Date
00	n/a	10.2006
01	12226	08.2010
02	13569	09.2012
03		06.2013
04	14780	09.2016
05	-	24-MAR-21

# Table of Contents

<b>Operation</b> .....	<b>3</b>
<b>Exploded Parts Diagram</b> .....	<b>5</b>
<b>Replacement Parts List</b> .....	<b>6</b>
<b>Wiring Diagram</b> .....	<b>7</b>
DFI2309 MOD ~ to B .....	7
DFI2309 MOD C to E .....	8
DFI2309 MOD F .....	9
DFI2310 MOD ~ .....	10
DFI2310 MOD A to E .....	11
DFI2310 MOD F .....	12
<b>Universal Replacement Procedures</b> .....	<b>13</b>
Partially Reflective Glass Replacement .....	13
Switch Replacement .....	13
Heater Assembly/Cutout Replacement .....	14
Heater Assembly Replacement .....	14
Power Cord Replacement .....	15
<b>Model / MOD Specific Procedures</b> .....	<b>16</b>
Light Bulb Replacement .....	16
Flicker Motor/Flicker Rod Replacement .....	17
Remote Control Receiver Replacement .....	18
Light Harness Replacement .....	19
Log Driver Board Replacement .....	20
<b>Troubleshooting Guide</b> .....	<b>22</b>

# Operation

## Electric Fireplace Manual Control

The manual controls for the unit are located in the top, right corner, on the front of the firebox (Figure 1). A switch is in the On position when the side with the “ I ”, or “ II ” markings on it is pushed in.

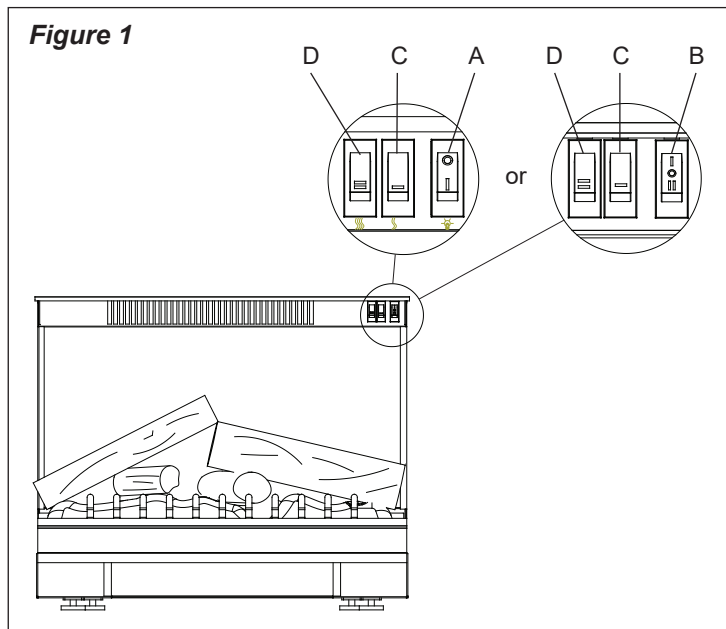

### Heat Switches (all models, all MOD levels)

#### Figure 1-C - Low Heat Switch (“ I ”)

The Low Heat On/Off Switch supplies power to the heater fan and the heater element. When the switch is in the On (“ I ”) position the heater operates on Low.

#### Figure 1-D - High Heat Switch (“ II ”)

The High Heat Switch supplies power to the heater fan and the heater element, when the switch is in the On (“ II ”) position the heater operates on High. The C - Low Heat Switch must also be in the On position for the high heat setting to operate.

**! NOTE:** If Switches C and D are in the Off position, only the flame effect will turn on when the power switch is activated.

### Main Power Switches (Figure 1-A & B)

#### A - On/Off Switch

Used in:

- DF12309 MODs ~ to B
- DF12310 MOD ~

The two (2) position On/Off Switch supplies power to all the fireplace functions.

#### B - On/Off/On Switch

Used in:

- DF12309 MODs C to D
- DF12310 MODs A to D

This three (3) position switch offers the following functions:

#### (I) Manual mode

When in the “ I ” position, the fireplace bypasses the built-in remote control, the flame effect is turned on and the electrical supply to the heater is controlled manually using the Low Heat and High Heat Switches (Figure 1-C and D).

#### (II) Remote mode

The “ II ” position is for operating the unit with the provided remote control. When in “ II ” position the unit is operated with the ON and OFF buttons of the remote control.

**! NOTE:** Remote control operates main power supply. Heat must still be controlled by switches on fireplace.

#### (O) Off position

All power to all functions are switched off.

### Resetting the Temperature Cutoff Switch

Should the fireplace overheat, an automatic cut out will turn the heater off and it will not come back on without being reset. It can be reset by switching the Main Power Switch (Figure 1-A or B) to the Off (“ O ”) position, and waiting five (5) minutes before switching the unit back on.

**! CAUTION:** If you need to continuously reset the heater, unplug the unit and call Dimplex North America Limited at 1-888-346-7539 for technical support.

### Remote Controls

The following plug-in remote control (Figure 2) is included with the models and MOD levels specified below:

Used in:

- DF12309 MODs ~ to B
- DF12310 MOD ~

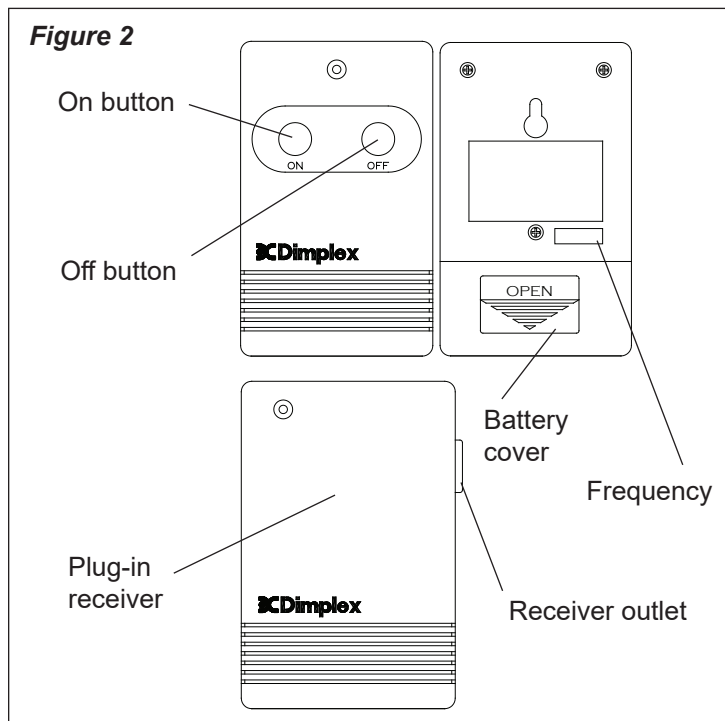

The remote control has a range of approximately 50 feet (15.25 m). It does not have to be pointed at the fireplace and can pass through most obstacles (including walls). It is supplied with one of 243 independent frequencies to prevent interference with other units and the frequency designation is indicated on the back of the remote control.

Replace battery when needed with a 9 volt battery.

#### Remote Control Installation

1. Plug fireplace power cord into the outlet located on the side of the receiver (Figure 2).
2. Plug receiver into the wall outlet.
3. Remove the plastic tag at the battery cover, to activate the remote control.

**! NOTE:** Fireplace Power On/Off Switch (Figure 1-A) must be in the On (“ I ”) position prior to using the Remote Control.

ON/OFF Remote Control may be used to control most other electrical devices including TV’s, stereos and lamps.

**⚠ CAUTION:** For indoor use in dry areas only.

For use on electrical devices with 15 amp resistive load or 1/3 HP inductive load.

120 volt AC only.

**! NOTE:** The plug-in remote version may include either the remote control as pictured on page 3 or the remote control as shown to the right.

The following integrated remote control (Figure 3) is included with the models and MOD levels specified below:

Used in:

- DFI2309 MODs C to D
- DFI2310 MOD A2 to D

**! NOTE:** Ensure that the fireplace’s 3 Position On/Off Switch (Figure 1-B) is set to the remote control (“ II ”)

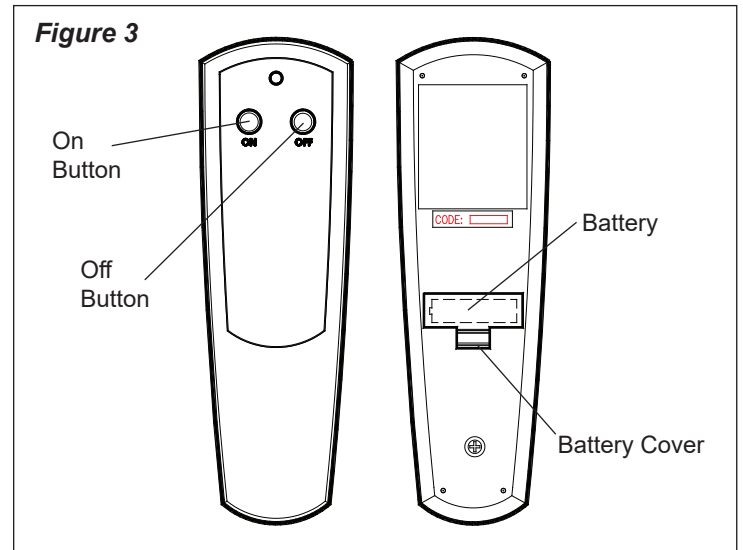

setting.

To operate: push **ON** button to turn fireplace on; push **OFF** button to turn fireplace off (Figure 3).

**! NOTE:** Remote control operates main power supply. Heat must still be controlled by Low Heat and High Heat switches on fireplace (Figure 1-C & D).

#### Battery Installation/Replacement

1. Depress tab on the battery cover on the back of the remote control and remove battery cover (Figure 3).
2. Properly orient and install one (1) 12 Volt (A23) battery into the remote control.
3. Replace the battery cover.

#### Remote Initialization

1. From an power off position, place the 3-Position Switch (Figure 1-B) into the Remote (“ II ”) position.
2. Within 10 seconds of step 1, press the ON button on the remote control.

This will synchronize the remote control with the receiver within the fireplace.

**! NOTE:** You will only have 10 seconds to perform the last step. If this is not completed within 5-10 seconds, the procedure will have to be repeated.

# Exploded Parts Diagram

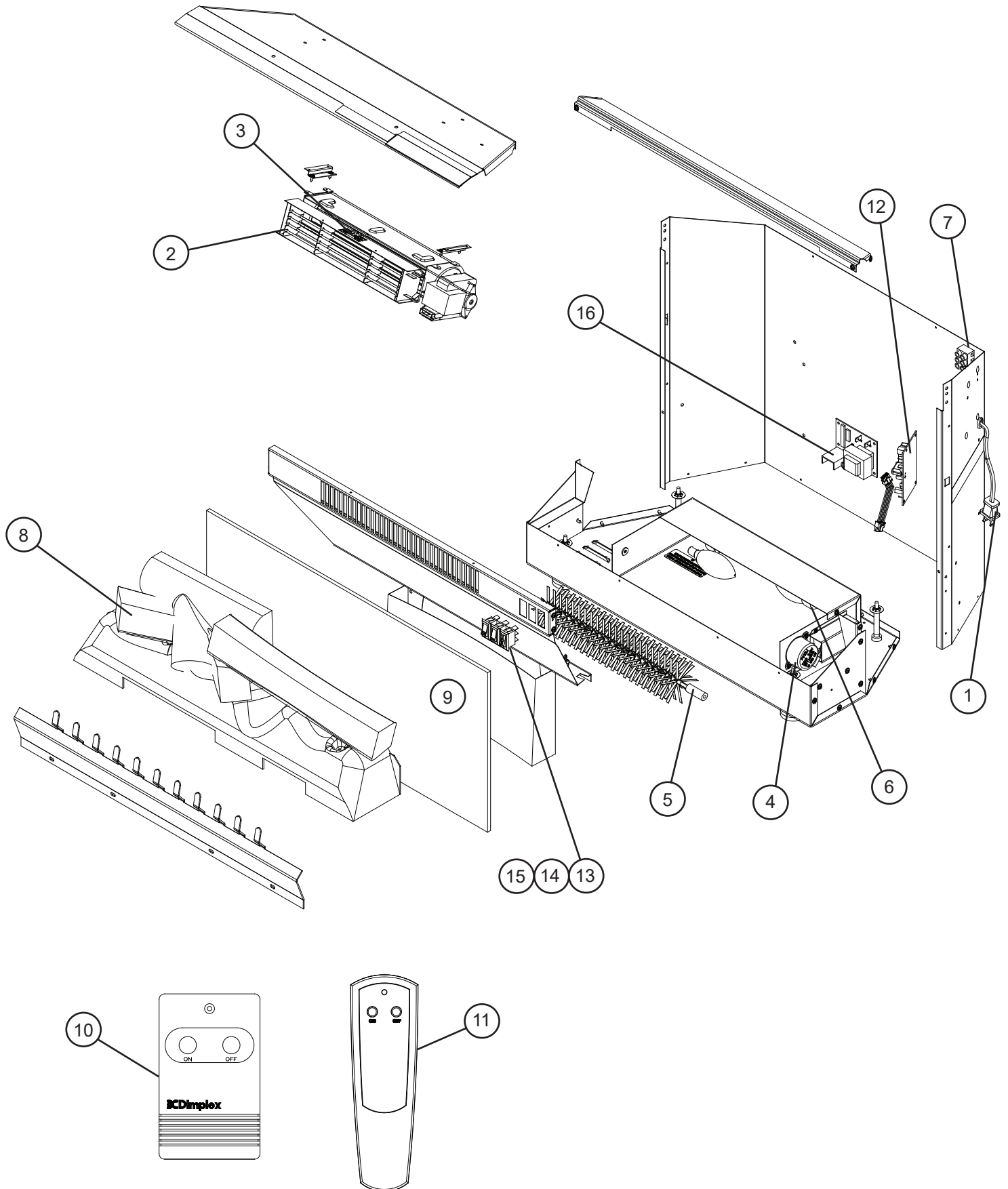

# Replacement Parts List

DFI2309 - Part Number ..... 6901470159

DFI2310 - Part Number ..... 6901470259

## Replacement Parts for both DFI2309, DFI2310 all MODs:

1. Power Cord ..... 4100090201RP
2. Heater Assembly ..... 2200490800RP
3. Cutout ..... 2300270200RP
4. Flicker Motor ..... 2000500100RP
5. Flicker Rod ..... 5900340100RP
6. Lampholder ..... 4200121000RP
7. Terminal block ..... 4000070100RP

## Non-Universal Replacement Parts

8. Log set  
DFI2309 MOD ~ to C ..... 0438200200RP  
DFI2309 MOD D ..... 0438200800RP  
DFI2310 MOD ~ to D ..... 0439230200RP
9. Partially reflective glass  
DFI2309 all MODs ..... 5900350100RP  
DFI2310 all MODs ..... 5900350200RP
10. 2 Piece Plug-in Remote Control  
DFI2309 MOD ~ to B ..... 680024RPNEW  
DFI2310 MOD ~ ..... 680024RPNEW
11. Integrated Remote Control  
DFI2309 MOD C to D ..... 3000370500RP  
DFI2310 MOD A to D ..... 3000370500RP
12. Integrated Remote Control Receiver  
DFI2309 MOD C to D ..... 3000380200RP  
DFI2310 MOD A to D ..... 3000380200RP
13. Main Power Switch  
DFI2309 MOD ~ to A ..... 2800090100RP\*  
DFI2309 MOD B ..... 2800070700RP  
DFI2309 MOD C to D ..... 2800071100RP  
DFI2310 MOD ~ ..... 2800070700RP  
DFI2310 MOD A to D ..... 2800071100RP
14. Low Heat Switch  
DFI2309 MOD ~ to A ..... 2800090100RP\*  
DFI2309 MOD B to D ..... 2800070900RP  
DFI2310 MOD ~ ..... 2800090100RP\*  
DFI2310 MOD A to D ..... 2800070900RP
15. High Heat Switch  
DFI2309 MOD ~ to A ..... 2800090100RP\*  
DFI2309 MOD B to D ..... 2800071000RP  
DFI2310 MOD ~ ..... 2800090100RP\*  
DFI2310 MOD A to D ..... 2800071000RP
16. LED Log Driver (DFI2310 only) ..... 3000390100RP

# Wiring Diagram

## DFI2309 MOD ~ to B

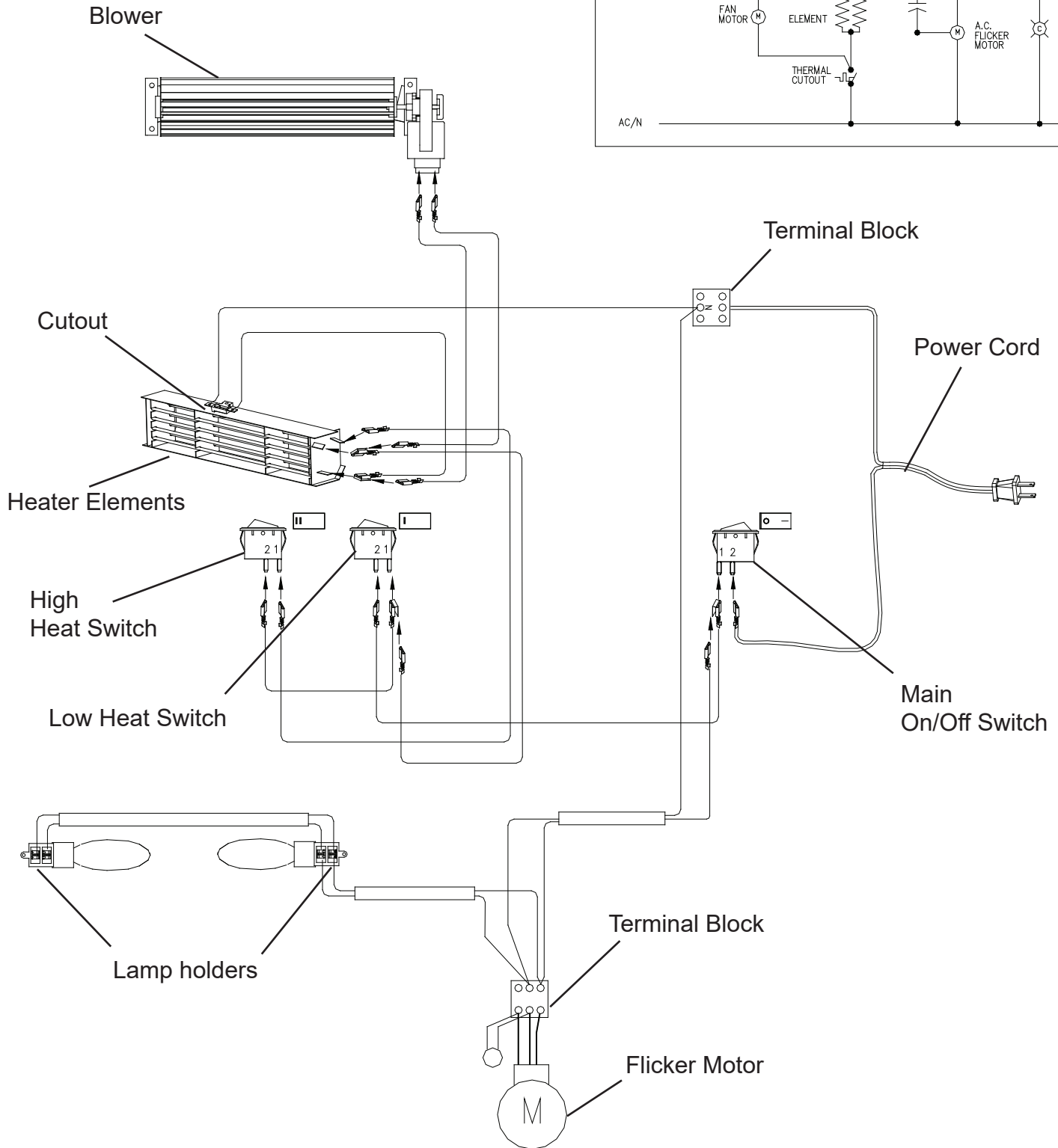
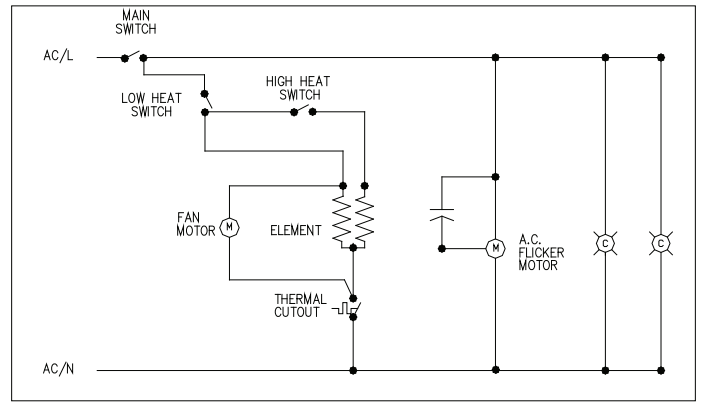





# Wiring Diagram DFI2309 MOD F

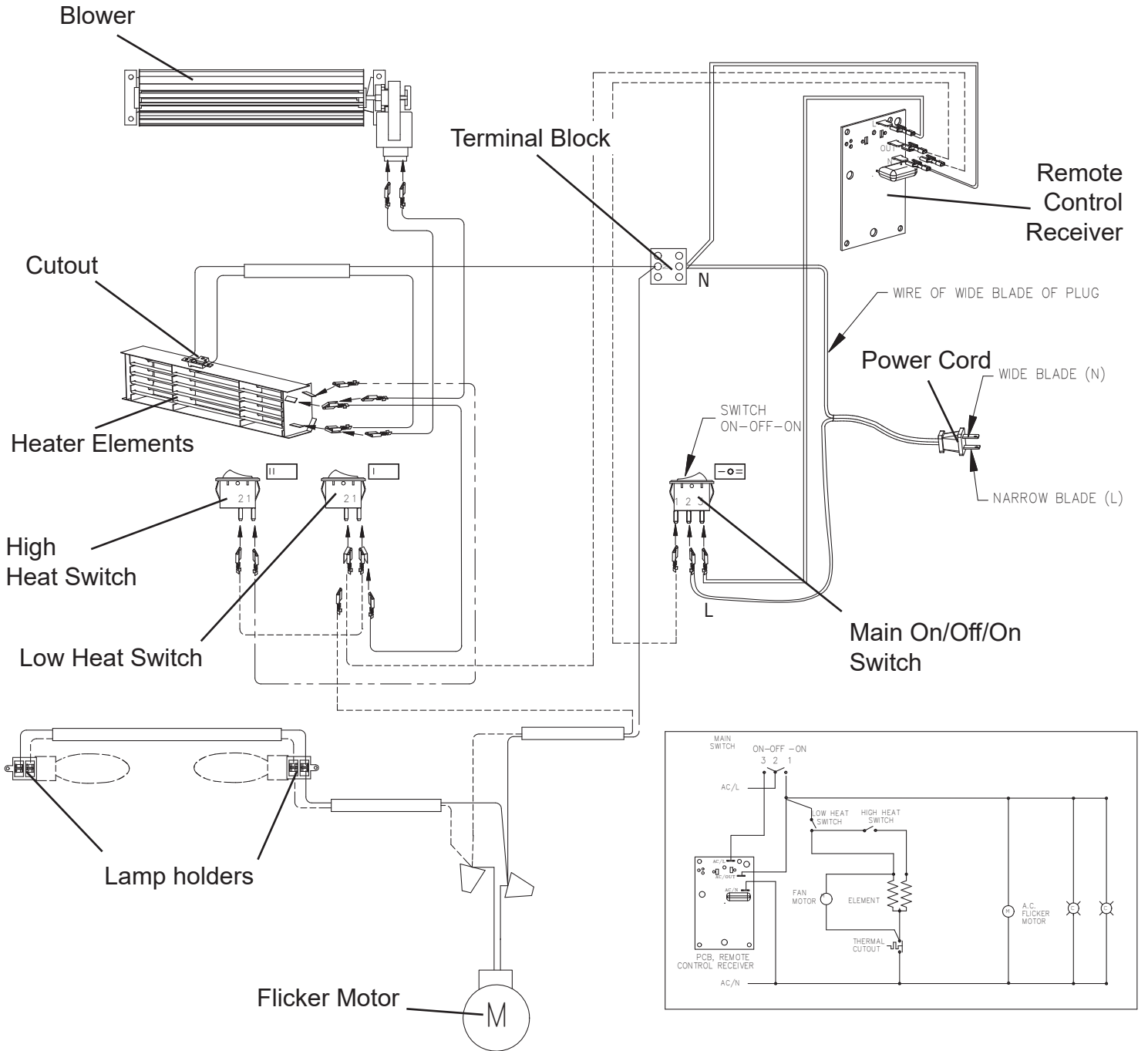

# Wiring Diagram DFI2310 MOD ~

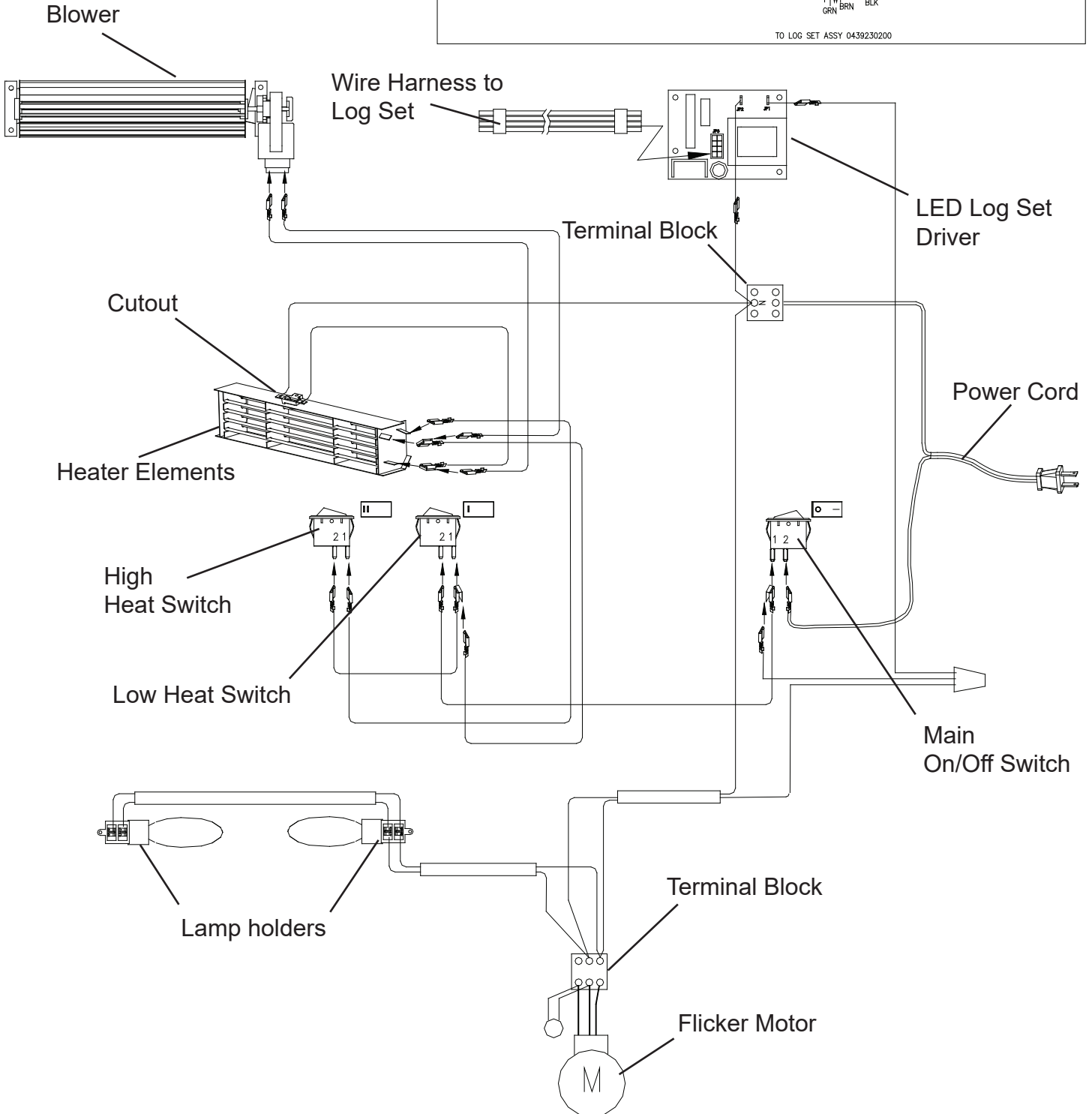
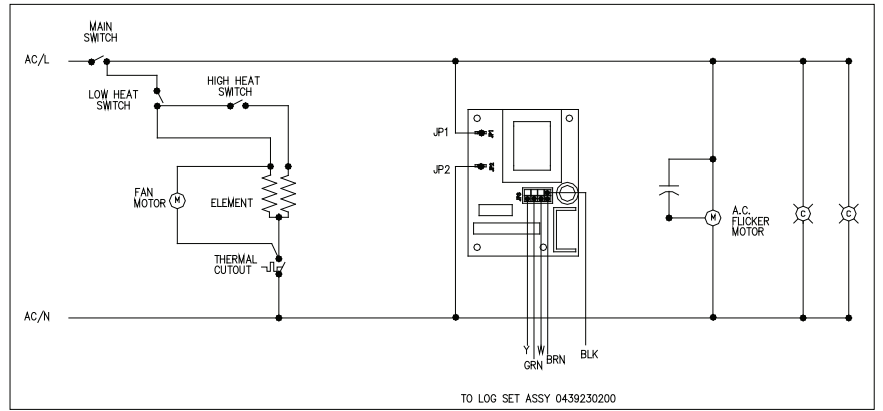

# Wiring Diagram

## DFI2310 MOD A to E

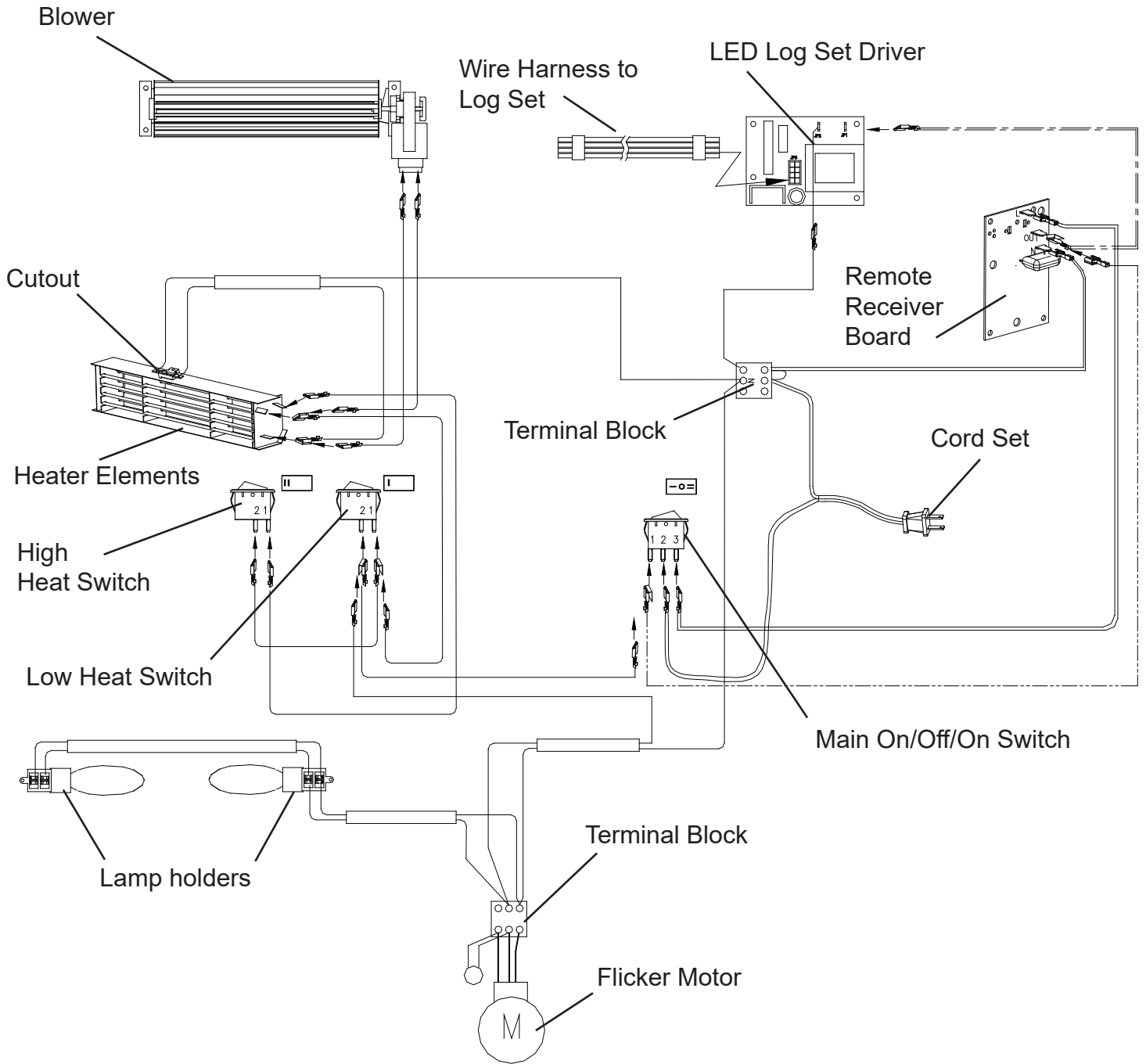
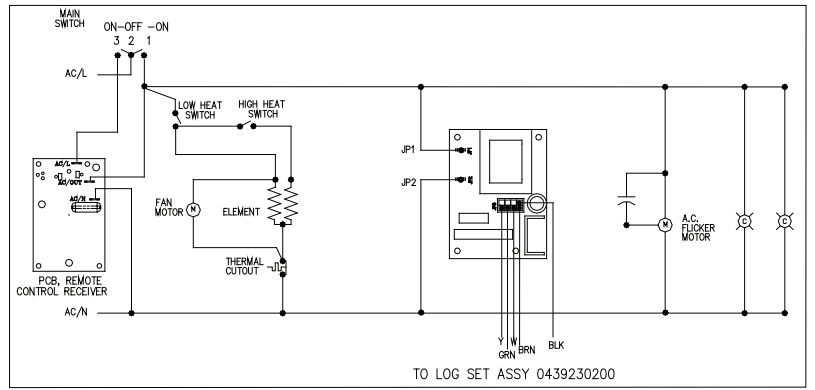

# Wiring Diagram DFI2310 MOD F

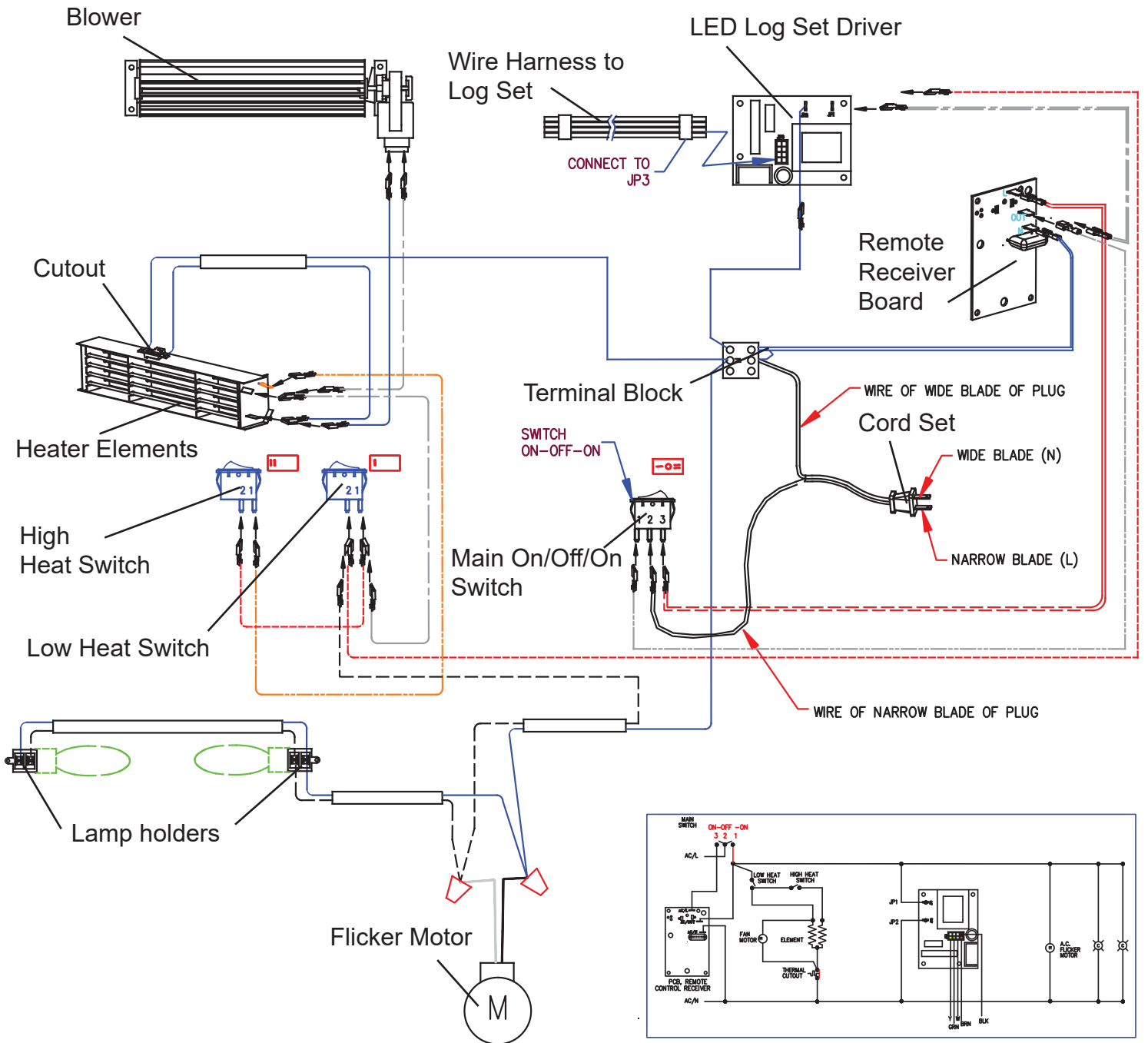

# Universal Replacement Procedures

## Partially Reflective Glass Replacement

If the firebox was operating prior to servicing allow at least five (5) minutes for light bulbs and heating element to cool off to avoid accidental burning of skin.

Disconnect power before attempting any maintenance or cleaning to reduce the risk of electric shock or damage to persons.

### Replacement Procedure

1. Disconnect power and remove firebox from mantel or existing fireplace.
2. Remove four (4) Phillips screws from the top and rear, upper edge of the firebox as shown in Figure 4-A. This will release the top cover from the firebox.

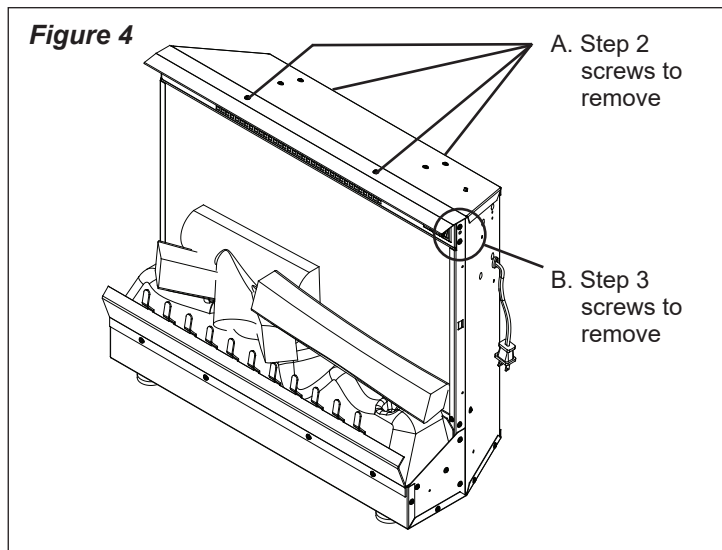

3. Tilt the top cover of the firebox up and either prop the cover against a stationary object or situate it in such a way that there is access to the upper section of the firebox.
4. Remove one (1) or two (2) Phillips screws from each upper corner of the firebox as shown in Figure 4-B. Quantity will differ by model and MOD level.
5. Gently push the switch control panel inwards until top edge of partially reflective glass is exposed (Figure 5).
6. Slide partially reflective glass up to remove.
7. Properly orient replacement partially reflective glass and slide it down into place behind Log Set.
8. Re-assemble firebox in reverse order as above.

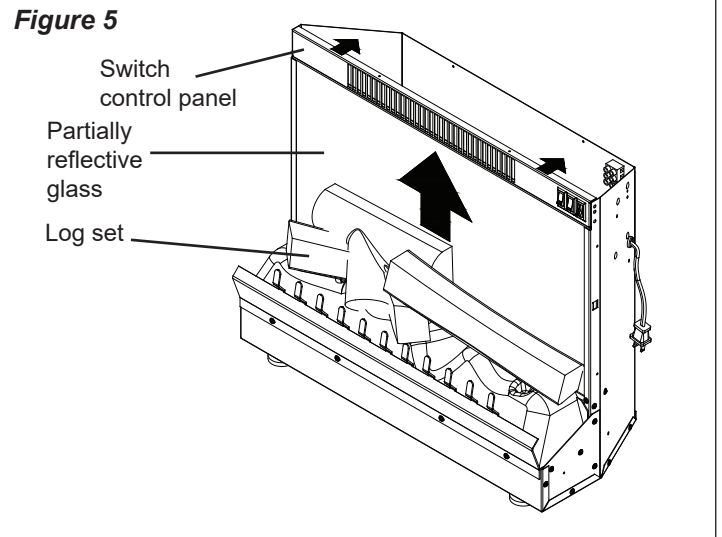

## Switch Replacement

If the firebox was operating prior to servicing allow at least five (5) minutes for light bulbs and heating element to cool off to avoid accidental burning of skin.

Disconnect power before attempting any maintenance or cleaning to reduce the risk of electric shock or damage to persons.

Each of the three (3) switches (Main Power Switch, Low Heat Switch and High Heat Switch) will have the same replacement procedure.

### Replacement Procedure:

1. Disconnect power and remove firebox from mantel or existing fireplace.
2. Remove four (4) Phillips screws from the top and rear, upper edge of the firebox as shown in Figure 4-A. This will release the top cover from the firebox.
3. Tilt the top cover of the firebox up and either prop the cover against a stationary object or situate it in such a way that there is access to the upper section of the firebox.
4. Remove all wiring clips and connections from the switch to be replaced, noting their original locations (Figure 6).

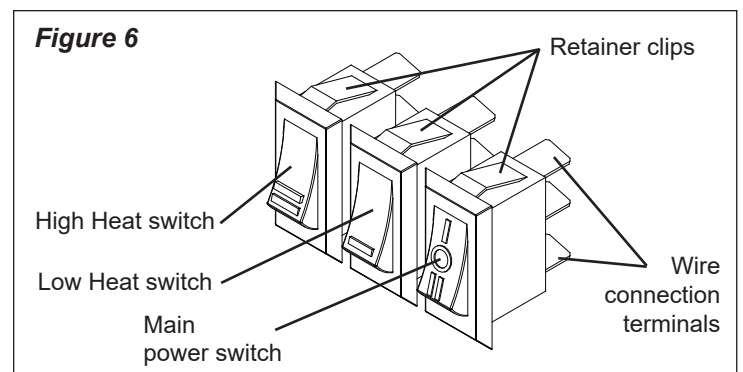

**! NOTE:** It may be necessary to remove all wire clips and/or switches in order to provide sufficient working room

within the firebox. Be sure to note each wire's original location carefully.

5. Remove the switch by depressing the retaining clips (Figure 6) and pushing the switch forward, through the sheet metal of the firebox.

**! NOTE:** Due to the switches' placement under the lip of sheet metal, it may be necessary to use a large flat-headed screwdriver to slide between the switch and sheet metal in order to depress the top retaining clip.

6. Properly orient replacement switch and push through sheet metal of firebox until retaining clips snap into place.
7. Re-connect wiring clips removed in step 5.

**⚠ WARNING:** Improper re-connection of wiring may result in electric shock, fire, or injury to persons. Ensure that connections to/from switches match those of the respective wiring diagram for the particular model and MOD level being serviced (pages 7-10).

9. Re-assemble firebox following steps 1-3 in reverse order.

## Heater Assembly/Cutout Replacement

If the firebox was operating prior to servicing allow at least five (5) minutes for light bulbs and heating element to cool off to avoid accidental burning of skin.

Disconnect power before attempting any maintenance or cleaning to reduce the risk of electric shock or damage to persons.

### Replacement Procedure

1. Disconnect power and remove firebox from mantel or existing fireplace.
2. Remove four (4) Phillips screws from the top and rear, upper edge of the firebox as shown in Figure 4-A. This will release the top cover from the firebox.
3. Lift the top cover of the firebox up carefully - the heater assembly is attached to the underside of the top cover.
4. Using side cutters, cut all zip ties that bind wires together
5. Hold the heater assembly in one hand (or have another person assist), and remove four (4) Phillips screws from the top cover to release the heater assembly from the top cover (Figure 7).

### Cutout Replacement

- i) Follow the two (2) wires leading from the cutout and disconnect them from their respective terminals.

**! NOTE:** The shorter wire from the cutout has a piggy-back connection at the heater element as shown in Figure 8. Disconnect the piggy-back connection as well as the secondary wire that connects to the blower motor terminal.

To remove the longer wire from the terminal block, use

**Figure 7**

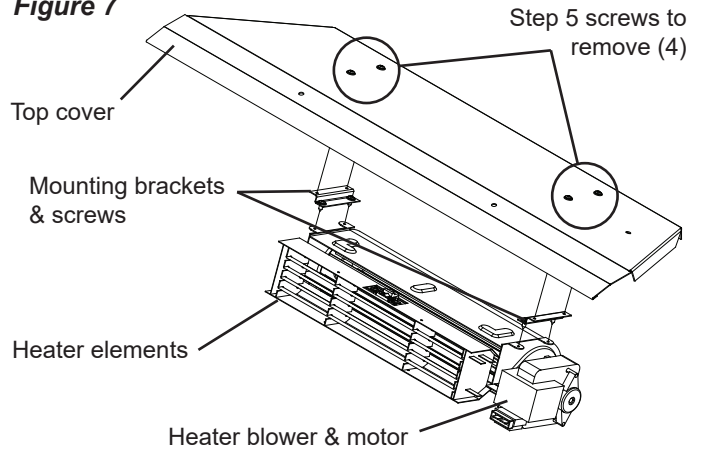

**Figure 8**

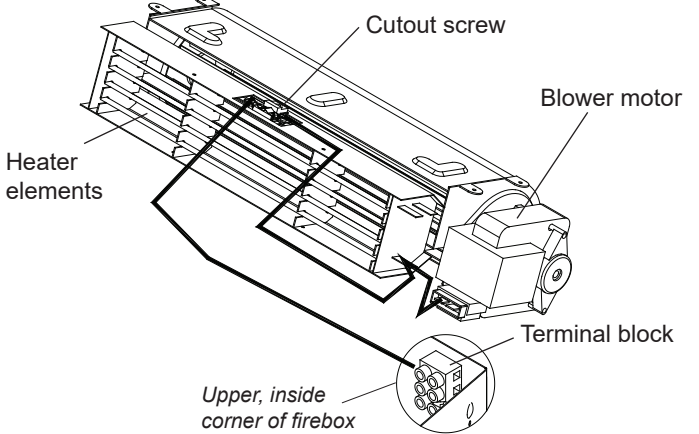

a small Phillips screwdriver to loosen the screw which clamps the wire from the cutout to the terminal block.

- ii) With wires loose from their connections, remove the small Phillips screw that attaches the cutout to the heater assembly (Figure 8). Remove and discard old cutout.
  - iii) Attach replacement cutout to heater assembly using screw from step ii.
  - iv) Connect piggy-back wire as shown in Figure 8.
  - v) Connect long, single-ended wire to terminal block. Ensure that black power wire leading to lower section of firebox (and any other wires disconnected from terminal block in step i) is connected with wire lead from cutout. Tighten down on terminal block with small Phillips screwdriver.
- ⚠ WARNING:** Improper re-connection of wiring may result in electric shock, fire, or injury to persons. Ensure that connections to/from cutout match those of the respective wiring diagram for the particular model and MOD level being serviced (pages 7-10).
- vi) If servicing is complete, follow steps 1-5 in reverse order.

## Heater Assembly Replacement

- i) Remove the one (1) small Phillips screw which attaches the cutout to the heater assembly (Figure 8).

- ii) Remove the two (2) piggy-back and three (3) single wire connectors from the heater element and motor, noting their original locations.
- iii) Remove the two (2) Phillips screws from each of the two (2) mounting brackets as shown in Figure 7. Do not discard brackets.
- iv) Attach the two (2) mounting brackets to the replacement heater assembly in the same orientation as in Figure 7, using two (2) Phillips screws removed in step iii.
- v) Using the single small Phillips screw from step i, attach the cutout to the replacement heater assembly.
- vi) Attach the piggy-back wire from the cutout as shown in Figure 8: piggy-back connectors to the lower terminal of the heater element, then on to the inner-most terminal of the blower motor.
- vii) Attach the last two (2) wires removed in step ii: yellow wire will run from the high heat switch to the top, front-most terminal; the grey piggy-back wire will run from the low heat switch to the top, inner-most terminal of the heater element then piggy-back to the outer terminal of the blower motor (Figure 9).

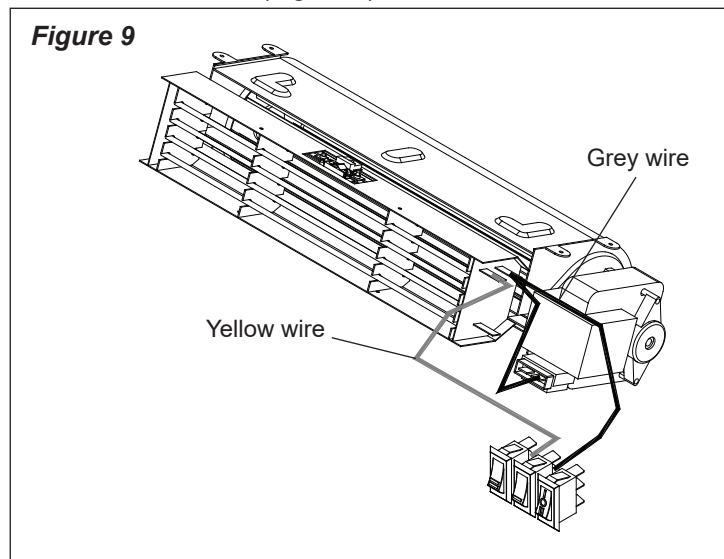

## Power Cord Replacement

If the firebox was operating prior to servicing allow at least five (5) minutes for light bulbs and heating element to cool off to avoid accidental burning of skin.

Disconnect power before attempting any maintenance or cleaning to reduce the risk of electric shock or damage to persons.

### Replacement Procedure:

1. Disconnect power and remove firebox from mantel or existing fireplace.
2. Remove four (4) Phillips screws from the top and rear, upper edge of the firebox as shown in Figure 4-A. This will release the top cover from the firebox.
3. Lift the top cover of the firebox up carefully - the heater assembly is attached to the underside of the top cover.
4. Follow the power cord through the firebox chassis and cut all zip ties that bind the two (2) wires of the power cord using side cutters.

5. Disconnect the power cord wire which leads to the Main Power On/Off (or 3-Position) Switch. This should be the only black wire going to this switch (Figure 10).
6. Use a small Phillips screwdriver to loosen the screw which clamps the other power cord lead into the terminal block (Figure 10). Make note of any additional wires that were clamped together with power cord.
7. To remove power cord from chassis, use needle nose pliers to squeeze sides of cable clamp and pull through chassis of firebox, removing clamp and cable.

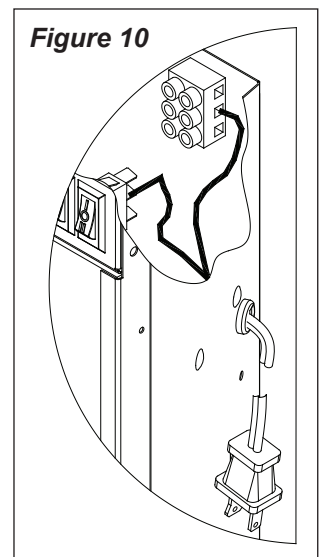

**⚠ WARNING:** Improper re-connection of wiring may result in electric shock, fire, or injury to persons. Ensure that connections to/from heater assembly and switches match those of the respective wiring diagram for the particular model and MOD level being serviced (pages 7-10).

**! NOTE:** The wire colors referenced in these instructions may not be the same as those used in all fireboxes. Ensure that all wiring matches original placement and/or the wiring diagrams that are supplied in this manual.

- viii) Follow steps 1 through 5 in reverse order to reassemble firebox.

8. Remove clamp from cable and attach to replacement cord, leaving approximately eight (8) inches (20 cm) of slack to wire ends (orient clamp in same manner with tapered side facing wire ends).
9. Feed replacement power cord through chassis hole and using pliers, squeeze sides of cable clamp to push clamp into sheet metal until snaps in place.
10. Connect terminated wire end to Main Power Switch.
11. Connect crimped wire end to terminal block where original was removed (step 6). Also ensure any wires freed in step 6 are clamped together with power cord wire.
12. Follow steps 1 through 3 in reverse order to reassemble firebox.



# Model / MOD Specific Procedures

## Light Bulb Replacement

Allow at least five (5) minutes for light bulbs to cool before touching bulbs to avoid accidental burning of skin.

Light bulbs need to be replaced when you notice a dark section of the flame. There are two (2) bulbs under the log set which generate the flames and embers.

Disconnect power before attempting any maintenance or cleaning to reduce the risk of electric shock or damage to persons.

### Helpful Hints

It is a good idea to replace all light bulbs at one time if they are close to the end of their rated life. Group replacement will reduce the number of times you need to open the unit to replace light bulbs.

### Light Bulb Requirements

Quantity of two (2) clear chandelier or candelabra bulbs with an E-12 (small) socket base, 60 Watt rating.

**Do not exceed 60 Watts per bulb**

### Replacement Procedure for:

#### DFI2309 & DFI2310 MODs ~ to C

1. Remove the two (2) outer Phillips screws on the log grate at the front of the firebox as shown in Figure 11.

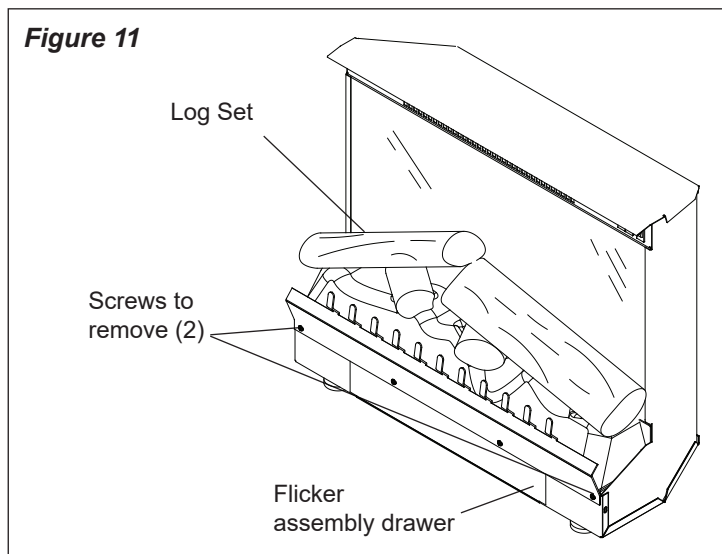

2. Pull the flicker assembly drawer out approximately 1½ inches (4 cm), or until it stops.
3. Carefully remove the Log Set from the firebox.
4. Disconnect LED harness to Log Set (*DFI2310 only*). Set Log Set aside (Figure 12).
5. Pull Flicker Rod to the far right, towards the Flicker Motor,

Figure 12

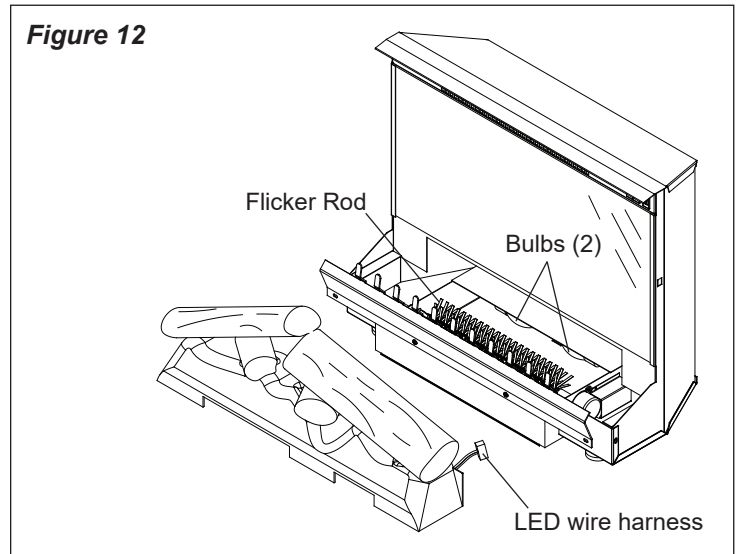

carefully bend the Flicker Rod enough to release the opposite end from the mounting bracket (Figure 12).

6. Pull Flicker Rod off of the shaft of the Flicker Motor and set aside.
  7. Remove bulb(s) by turning counter-clockwise and replace.
  8. Push rubber grommet of Flicker Rod back onto shaft of Flicker Motor and carefully bend Flicker Rod so as to insert opposite end back into mounting bracket.
- ! NOTE:** If Flicker Rod is bent out of alignment, carefully bend it back to become straight. If Flicker Rod is not properly aligned, it may cause noise during operation by rubbing against metal chassis.
9. Follow steps 1 through 4 in reverse order to reassemble firebox.

### Replacement Procedure for:

#### DFI2309 & DFI2310 MODs ~ to C

1. Remove the four (4) Phillips screws on the log grate at the front of the firebox as shown in Figure 13.

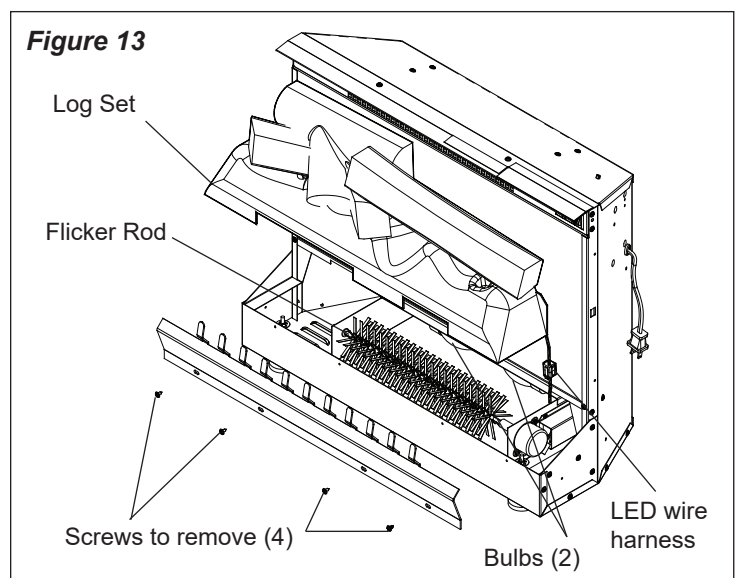



2. Carefully remove the Log Set from the firebox.
3. Disconnect LED harness to Log Set (*DFI2310 only*). Set Log Set aside (Figure 12).
4. Pull Flicker Rod to the far right, towards the Flicker Motor, carefully bend the Flicker Rod enough to release the opposite end from the mounting bracket (Figure 12).
5. Pull Flicker Rod off of the shaft of the Flicker Motor and set aside.
6. Remove bulb(s) by turning counter-clockwise and replace.
7. Push rubber grommet of Flicker Rod back onto shaft of Flicker Motor and carefully bend Flicker Rod so as to insert opposite end back into mounting bracket.

**! NOTE:** If Flicker Rod is bent out of alignment, carefully bend it back to become straight. If Flicker Rod is not properly aligned, it may cause noise during operation by rubbing against metal chassis.

8. Follow steps 1 through 3 in reverse order to reassemble firebox.

## Flicker Motor/Flicker Rod Replacement

If the fireplace was operating prior to servicing allow at least five (5) minutes for light bulbs and heating element to cool off to avoid accidental burning of skin.

Disconnect power before attempting any maintenance or cleaning to reduce the risk of electric shock or damage to persons.

### Replacement Procedure for:

#### DFI2309 & DFI2310 MODs ~ to C

1. Remove the two (2) outer Phillips screws on the log grate at the front of the firebox as shown in Figure 11.
2. Pull the flicker assembly drawer out approximately 1½ inches (4 cm), or until it stops.
3. Carefully remove the Log Set from the firebox.
4. Disconnect LED harness to Log Set (*DFI2310 only*). Set Log Set aside (Figure 12).
5. Pull Flicker Rod to the far right, towards the Flicker Motor, carefully bend the Flicker Rod enough to release the opposite end from the mounting bracket (Figure 12).
6. Pull Flicker Rod off of the shaft of the Flicker Motor and set aside.
7. Lift flicker assembly drawer up and out so that metal stop tabs clear the front edge of the firebox. Pull the drawer out as far as possible without causing damage or disconnection to wires connected at back.
8. Remove the Terminal Block Cover by removing one (1) Phillips screw from each opposing corner of the cover (Figure 14).
9. Using a small Phillips screwdriver, loosen all three (3) of the left side terminals of the Terminal Block.

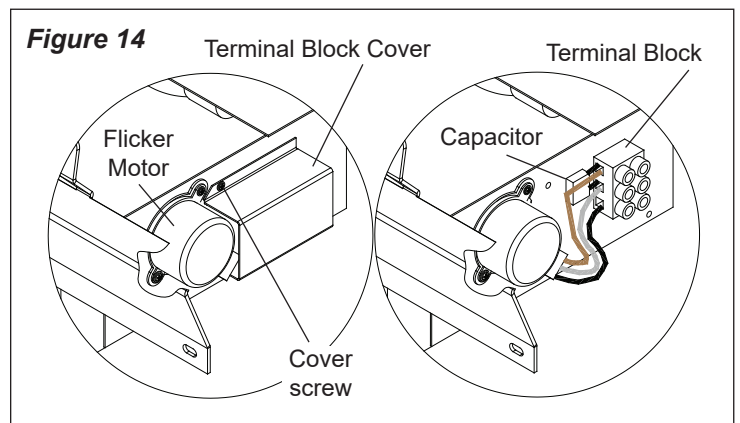

10. Remove the three (3) Flicker Motor wire leads from the Terminal Block, noting their original positions.

**! NOTE:** Do not misplace Capacitor.

11. Remove the two (2) Phillips screws that attach the Flicker Motor to the sheet metal. Remove and discard old Flicker Motor.
12. Ensure rubber spacer remains in place, properly orient replacement Flicker Motor and attach to sheet metal using screws removed in step 11.
13. Insert Flicker Motor wire leads into left side of Terminal Block as shown in Figure 14. Wire leads from Capacitor should align with brown and white wires from Flicker Motor.

**⚠ WARNING:** Improper re-connection of wiring may result in electric shock, fire, or injury to persons. Ensure that connections to/from Flicker Motor match those of the respective wiring diagram for the particular model and MOD level being serviced (pages 7-10).

14. Tighten down screws of all terminals using a small Phillips screwdriver.
15. Replace Terminal Block Cover using screws removed in step 8 and follow steps 1 through 7 in reverse order to reassemble firebox.

**! NOTE:** If Flicker Rod is bent out of alignment, carefully bend it back to become straight. If Flicker Rod is not properly aligned, it may cause noise during operation by rubbing against metal chassis.

### Replacement Procedure for:

#### DFI2309 & DFI2310 MODs D to F

1. Remove the four (4) Phillips screws on the log grate at the front of the firebox as shown in Figure 13.
2. Carefully remove the Log Set from the firebox.
3. Disconnect LED harness to Log Set (*DFI2310 only*). Set Log Set aside (Figure 12).
4. Pull Flicker Rod to the far right, towards the Flicker Motor, carefully bend the Flicker Rod enough to release the

opposite end from the mounting bracket (Figure 12).

5. Pull Flicker Rod off of the shaft of the Flicker Motor and set aside.
6. Turn firebox onto its back and remove the four (4) Phillips screws as shown in Figure 15.

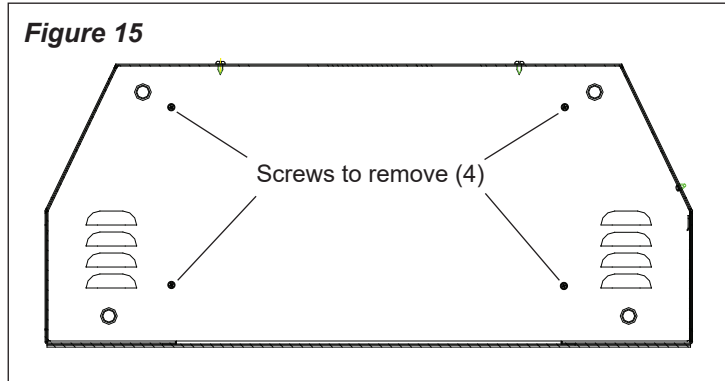

7. Turn firebox upright and gently pull the flicker and light assembly out of the firebox gently without causing damage or disconnection to the wiring at back.
8. Remove the Terminal Block Cover by removing one (1) Phillips screw from each opposing corner of the cover (Figure 16).

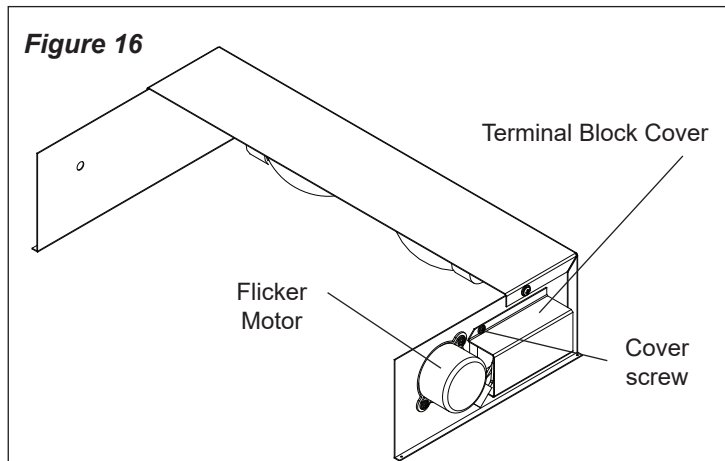
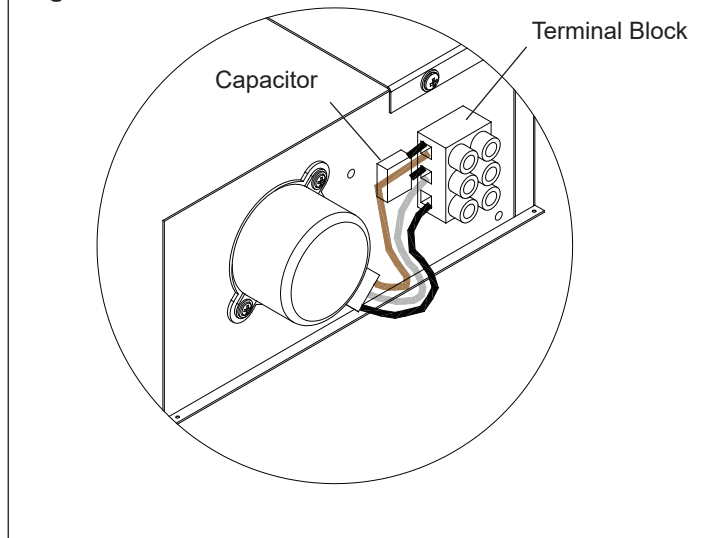

Figure 17



9. Using a small Phillips screwdriver, loosen all three (3) of the left side terminals of the Terminal Block.

- 10.a) If the new flicker motor has 3 wires: disconnect the wiring connections noting their original locations.

! **NOTE:** Do not misplace Capacitor.

- b) If the new flicker motor has 2 wires: disconnect the wiring connections and the capacitor, install the 2 wires in the two holes where the capacitor was installed.

! **NOTE:** The capacitor is not required in this instance.

- c) If the old and new flicker motors both have two wires, disconnect the wiring connections noting their original locations.

11. Remove the two (2) Phillips screws that attach the Flicker Motor to the sheet metal. Remove and discard old Flicker Motor.

12. Ensure rubber spacer remains in place, properly orient replacement Flicker Motor and attach to sheet metal using screws removed in step 11.

13. Insert Flicker Motor wire leads into left side of Terminal Block as shown in Figure 17. Wire leads from Capacitor should align with brown and white wires from Flicker Motor.

**⚠ WARNING:** Improper re-connection of wiring may result in electric shock, fire, or injury to persons. Ensure that connections to/from Flicker Motor match those of the respective wiring diagram for the particular model and MOD level being serviced (pages 7-10).

14. Tighten down screws of all terminals using a small Phillips screwdriver.

15. Replace Terminal Block Cover using screws removed in step 8 and follow steps 1 through 8 in reverse order to reassemble firebox.

! **NOTE:** If Flicker Rod is bent out of alignment, carefully bend it back to become straight. If Flicker Rod is not properly aligned, it may cause noise during operation by rubbing against metal chassis.

## Remote Control Receiver Replacement DFI2309/2310 MODs C to D

If the fireplace was operating prior to servicing allow at least five (5) minutes for light bulbs and heating element to cool off to avoid accidental burning of skin.

Disconnect power before attempting any maintenance or cleaning to reduce the risk of electric shock or damage to persons.

### Replacement Procedure:

1. Disconnect power and remove firebox from mantel or existing fireplace.

- Remove four (4) Phillips screws from the top and rear, upper edge of the firebox as shown in Figure 4-A. This

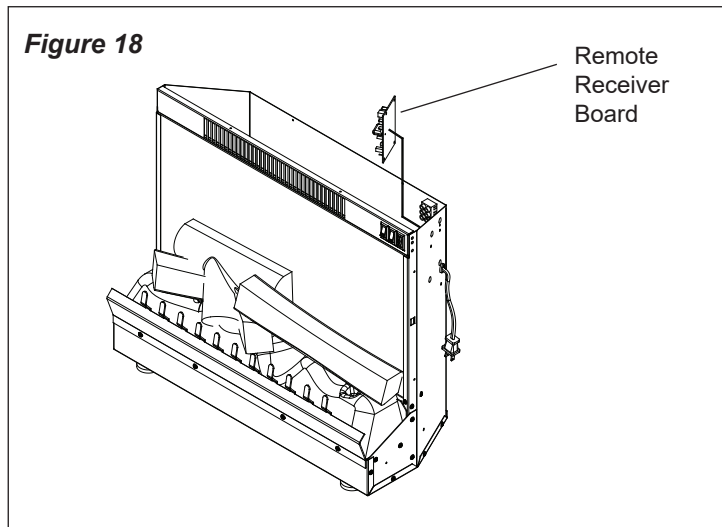

will release the top cover from the firebox.

- Tilt the top cover of the firebox up and either prop the cover against a stationary object or situate it in such a way that there is access to the upper section of the firebox.
  - The Remote Control Receiver is located on the side panel just above the entry point for the power cord (Figure 18).
  - Either pinch the clasp to release or cut each of the four (4) mounting studs (one in each corner of the Receiver Board) that attach the circuit board to the chassis of the firebox.
- ! NOTE:** If mounting studs are cut, ensure they are replaced by those supplied with replacement board.
- Clear both ends of mounting studs if cut.
  - Install replacement mounting studs (if necessary) by pushing them through the sheet metal from the outside of the firebox.
  - Properly orient replacement Receiver Board and push onto mounting studs until all four (4) snap closed.
  - Remove one wire terminal from original Receiver Board and install onto replacement Receiver Board, matching its original position.
  - Continue with remaining wire connections, moving one wire at a time, matching its original position.

**⚠ WARNING:** Improper re-connection of wiring may result in electric shock, fire, or injury to persons. Ensure that connections to/from circuit board match those of the respective wiring diagram for the particular model and MOD level being serviced (pages 7-10).

- Once all connections are made, follow steps 1 and 2 in reverse order to reassemble the firebox.

## Light Harness Replacement

If the fireplace was operating prior to servicing allow at least five (5) minutes for light bulbs and heating element to cool off to avoid accidental burning of skin.

Disconnect power before attempting any maintenance or cleaning to reduce the risk of electric shock or damage to persons.

### Replacement Procedure for:

#### DFI2309 & DFI2310 MODs ~ to C

- Disconnect power and remove firebox from mantel or existing fireplace.
- Remove the two (2) outer Phillips screws on the log grate at the front of the firebox as shown in Figure 11.
- Pull the flicker assembly drawer out approximately 1½ inches (4 cm), or until it stops.
- Carefully remove the Log Set from the firebox.
- Disconnect LED harness to Log Set (*DFI2310 only*). Set Log Set aside (Figure 12).
- Pull Flicker Rod to the far right, towards the Flicker Motor, carefully bend the Flicker Rod enough to release the opposite end from the mounting bracket (Figure 12).
- Pull Flicker Rod off of the shaft of the Flicker Motor and set aside.

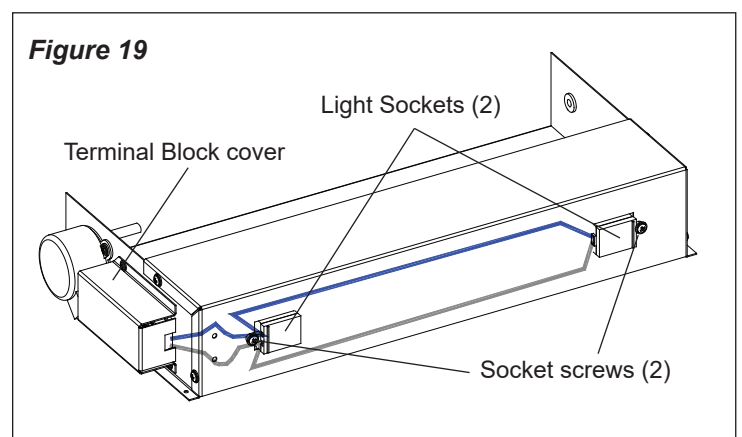

- Remove both light bulbs by turning counter-clockwise.
- Lift flicker assembly drawer up and out so that metal stop tabs clear the front edge of the firebox. Pull the drawer out as far as possible without causing damage to wires connected at back.

10. Using side cutters, cut the two (2) light harness wires (blue, white) in between the Terminal Block cover and the right light socket (Figure 19). Leave as much slack as possible.
11. Strip ½ inch (1.3 cm) off the ends of the two (2) light harness wires on the flicker motor cover side.
12. Cut the two (2) light harness wires (blue, white) in between the left and right light sockets.
13. Remove the two (2) Phillips light socket screws from the rear of the light assembly (Figure 19).
14. Remove light sockets by placing a hand inside light assembly, grasping light socket and pulling light socket

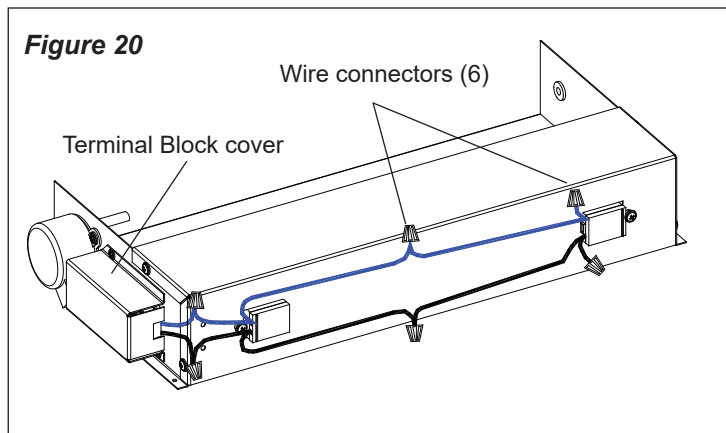

- until it snaps out of place.
15. Feed wires of replacement light sockets through holes in sheet metal, properly orient and push light sockets in until they snap into place.
  11. Use the supplied wire connectors to connect light socket wires (blue to blue) (white to white) in between the two (2) light sockets as shown in Figure 20. Cut and cap the outer wires (1 white, 1 blue) with a wire connector (Figure 20).
  12. Finally, use wire connectors to connect the light harness wires (blue to blue) (white to white) in between the Terminal Block cover and the right light socket.
  13. Follow steps 1 through 9 in reverse order to reassemble the firebox.

### Replacement Procedure for: DFI2309 & DFI2310 MODs D

1. Disconnect power and remove firebox from mantel or existing fireplace.
2. Remove the four (4) Phillips screws on the log grate at the front of the firebox as shown in Figure 13 and remove log grate.
3. Carefully remove the Log Set from the firebox.
4. Disconnect LED harness to Log Set (*DFI2310 only*). Set Log Set aside (Figure 12).
5. Pull Flicker Rod to the far right, towards the Flicker Motor,

- carefully bend the Flicker Rod enough to release the opposite end from the mounting bracket (Figure 12).
6. Pull Flicker Rod off of the shaft of the Flicker Motor and set aside.
7. Turn firebox onto its back and remove the four (4) Phillips screws as shown in Figure 15.
8. Turn firebox upright and gently pull the flicker and light assembly out of the firebox gently without causing damage to the wiring at back.
9. Remove both light bulbs by turning counter-clockwise.
10. Using side cutters, cut the two (2) light harness wires (blue, white) in between the Terminal Block cover and the right light socket (Figure 19). Leave as much slack as possible.
11. Strip ½ inch (1.3 cm) off the ends of the two (2) light harness wires on the flicker motor cover side.
12. Cut the two (2) light harness wires (blue, white) in between the left and right light sockets.
13. Remove the two (2) Phillips light socket screws from the rear of the light assembly (Figure 19).
14. Remove light sockets by placing a hand inside light assembly, grasping light socket and pulling light socket until it snaps out of place.
15. Feed wires of replacement light sockets through holes in sheet metal, properly orient and push light sockets in until they snap into place.
11. Use the supplied wire connectors to connect light socket wires (blue to blue) (white to white) in between the two (2) light sockets as shown in Figure 20. Cut and cap the outer wires (1 white, 1 blue) with a wire connector (Figure 20).
12. Finally, use wire connectors to connect the light harness wires (blue to blue) (white to white) in between the Terminal Block cover and the right light socket.
13. Follow steps 1 through 9 in reverse order to reassemble the firebox.

### Log Driver Board Replacement DFI2310 only - all MODs

If the fireplace was operating prior to servicing allow at least five (5) minutes for light bulbs and heating element to cool off to avoid accidental burning of skin.

Disconnect power before attempting any maintenance or cleaning to reduce the risk of electric shock or damage to persons.

#### Replacement Procedure:

1. Disconnect power and remove firebox from mantel or existing fireplace.

**Figure 21**

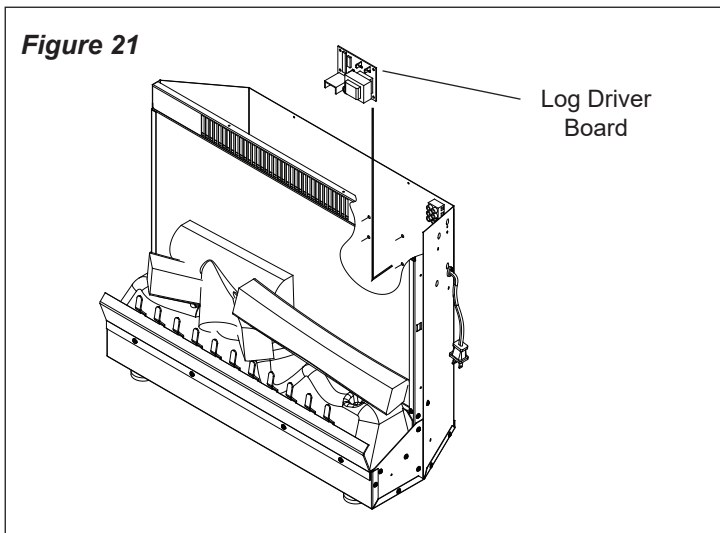

2. Remove four (4) Phillips screws from the top and rear, upper edge of the firebox as shown in Figure 4-A. This will release the top cover from the firebox.
3. Tilt the top cover of the firebox up and either prop the cover against a stationary object or situate it in such a way that there is access to the upper section of the firebox.
6. The Log Driver Board is located inside the firebox, on the back panel and just under the terminal block (Figure 21).
7. Either pinch the clasp to release or cut each of the four (4) mounting studs (one in each corner of the Log Driver Board) that attach the circuit board to the chassis of the firebox.

**! NOTE:** If mounting studs are cut, ensure they are replaced by those supplied with replacement board.

8. Clear both ends of mounting studs if cut.
9. Install replacement mounting studs (if necessary) by pushing them through the sheet metal from the outside of the firebox.
10. Properly orient replacement Log Driver Board and push onto mounting studs until all four (4) snap closed.
10. Remove one wire terminal from original Log Driver Board and install onto replacement Log Driver Board, matching its original position.
11. Continue with remaining wire connections, moving one wire at a time, matching its original position.

**⚠ WARNING:** Improper re-connection of wiring may result in electric shock, fire, or injury to persons. Ensure that connections to/from circuit board match those of the respective wiring diagram for the particular model and MOD level being serviced (pages 7-10).

12. Once all connections are made, follow steps 1 and 2 in reverse order to reassemble the firebox.



# Troubleshooting Guide

PROBLEM	CAUSE	SOLUTION
<b>General</b>		
Circuit breaker trips or fuse blows when unit is turned on	Short in unit wiring.	Trace wiring in unit.
	Improper circuit current rating	Additional appliances may exceed the current rating of the circuit breaker or fuse. Plug unit into another outlet or install unit on a dedicated 15 amp circuit.
Unit turns on or off by itself	Remote Control has a similar frequency to other remotes in the area.	Replace Remote Control. Initialize Remote Control and Remote Control Receiver
	Radio frequency disturbance from outside sources.	Replace Remote Control and Remote Control Receiver, where necessary. Initialize Remote Control and Receiver
Lights dim in room while the unit is on	Unit is drawing close to circuit current rating	Move the unit to another outlet or install unit on a dedicated 15 amp circuit
Power cord gets warm	Normal Operation	The power cord may get slightly warm to the touch when the heater is on
	Defective power cord	Replace power cord if cord gets hot to the touch.
<b>Appearance</b>		
Fireplace does not turn on Manually	Improper operation	Refer to Operation Section
	No incoming voltage from the electrical wall socket	Check Fuse/Breaker Panel
	Loose wiring	Check wiring connections
	Defective On/Off or 3-Position Switch	Replace On/Off or 3-Position Switch (Depending on the model)
	Defective Remote Control Receiver	Replace Remote Control Receiver. Initialize with Remote Control
Fireplace does not turn on using the Remote Control	Improper operation	Refer to Operation Section
	Remote Control not initialized to fireplace	Initialize the Remote Control
	Remote Control not working.	Install new battery into the Remote Control. Reinitialize remote where necessary Replace Remote Control or Remote Control Receiver, where necessary. Initialize Remote Control and Receiver.
Flame Frozen	Loose wiring	Check wiring connections
	Defective Flicker motor	Replace Flicker motor
Flame not bright or flame not visible	Burnt out light bulbs	Replace light bulbs
	Loose wiring	Check wiring connections
	Defective light harness	Replace light harness
Log set dim, not glowing	Burnt out light bulbs	Replace light bulbs
Flame Shudder	Defective Flicker motor	Replace Flicker motor
Light leaking around the log set	Log set not positioned properly	Check log set for proper fit

PROBLEM	CAUSE	SOLUTION
<b>Heater</b>		
Heater is not turning off	Improper operation	Refer to Operation Section
	Defective Heater Switches	Replace Heater Switch(es)
Heater is not turning on, but flame effect is still functioning	Improper operation	Refer to Operation Section
	Loose wiring	Trace wiring in unit.
	Defective Heater Switches	Replace Heater Switch(es)
	Defective Heater Assembly	Replace Heater Assembly
Heater is turning off after a couple of minutes of operation	Build up of dirt/dust in heater assembly	Ensure that exterior intake louvers and firebox cavity are free of dirt/dust.
	Defective Heater Assembly	Replace Heater Assembly
Heater emits an odor	Normal Operation	Normal operation is when the heater emits an odor for a brief period after the heater is initially turned on. The heater is burning off any dust accumulated during manufacturing or operation.
	Defective Heater Assembly	Replace Heater Assembly
Heater fan turns on but heater lacks heat	Improper operation	Refer to Operation Section
	Loose wiring	Trace wiring in unit
	Defective Heater Switches	Replace Heater Switch(es)
	Defective Heater Assembly	Replace Heater Assembly
Heating element is glowing red	Normal Operation	Small glowing sections of the element are considered normal.
	Defective Heater Assembly	If larger glowing sections are causing the heater to trip the thermal cutout, unplug unit, discontinue use and replace heater assembly.
<b>Noise</b>		
Excessive noise with the heater on	Dirty blower assembly	Ensure that exterior intake louvers and firebox cavity are free of dirt/dust.
	Defective Heater Assembly	Replace Heater Assembly
Grinding or excessive noise with the heater off	Flicker rod hitting or rubbing against internal components	Ensure rod is straight and mounted properly in the bracket, spinning freely away from other components. Replace if necessary.
	Defective Flicker motor	Replace Flicker motor

1-888-346-7539 | [www.dimplex.com](http://www.dimplex.com)

In keeping with our policy of continuous product improvement, we reserve the right to make changes without notice.

© 2021 Glen Dimplex Americas